

## Original Instruction Manual

**DP58P** Heavy Duty  
Pedestal Drill with 50"  
Column & 5/8" Chuck

**DP58B** Heavy Duty  
Bench Drill with 30"  
Column & 5/8" Chuck

Version 3.1  
April 2014



To register this product please visit  
**[www.recordpower.info](http://www.recordpower.info)**

It is important to register your product as soon as possible in order to receive efficient after sales support and be entitled to the full **5 year guarantee**. Your statutory rights are not affected. Please see back cover for contact details.



Always wear safety glasses when using woodworking equipment.



Always read the instructions provided before using woodworking equipment.

### Important

For your safety read instructions carefully before assembling or using this product.

Save this manual for future reference.







# Contents

- 1 Explanation of Symbols
  - 2 General Health & Safety Guidance
  - 3 Record Power Guarantee
  - 4 Specifications
  - 5 Contents of the Package
  - 6 Getting to Know Your Drilling Machine
  - 7 Assembly
  - 8 Operation
  - 9 Adjustments & Maintenance
  - 10 Electrical Connection & Wiring Diagram
  - 11 Dust Extraction
  - 12 Troubleshooting
  - 13 Parts Lists & Diagrams
- EU Declaration of Conformity





## 1. Explanation of Symbols

**THE SYMBOLS AND THEIR MEANINGS SHOWN BELOW MAY BE USED THROUGHOUT THIS MANUAL. PLEASE ENSURE THAT YOU TAKE THE APPROPRIATE ACTION WHEREVER THE WARNINGS ARE USED.**

### Mandatory Instructions

-  Read and fully understand the instruction manual before attempting to use the machine.
-  Indicates an instruction that requires particular attention
-  Wear protective eyewear
-  Use respiratory protective equipment
-  Use hearing protection
-  Use suitable protective footwear
-  Use protective work gloves

### Warning

-  Indicates a risk of severe personal injury or damage to the machine
-  Indicates a risk of severe personal injury from electrical shock
-  Risk of personal injury from lifting of heavy items
-  Indicates a risk of severe personal injury from airborne objects
-  Risk of fire

## 2. General Health & Safety Guidance

**Ensure that you carefully read and fully understand the instructions in this manual before assembly, installation and use of this product. Keep these instructions in a safe place for future reference.**

**WARNING:** for your own safety, do not attempt to operate this machine until it is completely assembled and installed according to these instructions.

**WARNING:** When using any machine, basic safety precautions should always be followed to reduce the risk of fire, electric shock and personal injury.

### Safe Operation

#### 1. Use Personal Protective Equipment (PPE)

- The operation of any machine can result in foreign objects being thrown into your eyes, which can result in severe eye damage. Protective eyewear or other suitable eye protection or face shield should be used at all times. Everyday spectacles only have impact resistant lenses. They are not protective eyewear and do not give additional lateral protection.
- Use respiratory protective equipment (dust mask etc.) if the machining operation creates dust. Exposure to high levels of dust created by machining hardwoods, softwoods and man made composite boards can result in serious health problems. Some imported hardwoods give off highly irritating dust, which can cause a burning sensation. The use of respiratory protective equipment should not be seen as an alternative to controlling the risk of exposure at source by using adequate dust extraction equipment.

- The use of ear plugs or ear defenders is recommended when the machine is in use, particularly if the noise level exceeds 85 dB.
- Wear suitable protective gloves when handling cutting tools or blades. Gloves should NOT be worn when using the machine as they can be caught in moving parts of the machine.
- Non-slip safety footwear is recommended when using the machine and handling large work pieces.

#### 2. Dress appropriately

- Do not wear loose clothing, neckties or jewellery; they can be caught in moving parts of the machine.
- Roll up long sleeves above the elbow.
- Wear protective hair covering to contain long hair.

#### 3. Safety warnings

- Find and read any warning labels on the machine
- It is important that any labels bearing health and safety warnings are not removed, defaced or covered. Replacement labels can be obtained by contacting our Customer Service Department.

#### 4. Familiarise yourself with the machine

- If you are not thoroughly familiar with the operation of this machine, obtain advice from your supervisor, instructor, or other qualified person or contact your retailer for information on training courses. Do not use this machine until adequate training has been undertaken.

#### 5. Take care when moving or positioning the machine

- Some machines can be very heavy. Ensure the floor of the area

## 2. General Health & Safety Guidance cont.

in which the machine is to be used is capable of supporting the machine.

- The machine and its various components can be heavy. Always adopt a safe lifting technique and seek assistance when lifting heavy components. In some cases it may be necessary to use mechanical handling equipment to position the machine within the work area.
- Some machines have optional wheel kits available to allow them to be manoeuvred around the workshop as required. Care should be taken to install these according to the instructions provided.
- Due to the nature of the design of some machines the centre of gravity will be high making them unstable when moved. Extreme care should be taken when moving any machine.
- If transportation of the machine is required then all precautions relating to the installation and handling of the machine apply. In addition, ensure that any vehicles or manual handling equipment used for transportation are of adequate specification.

### 6. The machine should be level and stable at all times

- When using a leg stand or cabinet base that is designed to be fitted to the machine, always ensure that it is securely fastened to the machine using the fixings provided.
- If the machine is suitable to be used on a workbench, ensure that the workbench is well constructed and capable of withstanding the weight of the machine. The machine should always be securely fastened to the workbench with appropriate fixings.
- Where possible, floor standing machines should always be secured to the floor with fixings appropriate to the structure of the floor.
- The floor surface should be sound and level. All of the feet of the machine should make contact with the floor surface. If they do not, either re-locate the machine to a more suitable position or use packing shims between the feet and the floor surface to ensure the machine is stable.

### 7. Remove adjusting keys and wrenches

- Ensure that all adjusting wrenches and keys are removed before switching the machine 'ON'. There is a risk of severe personal injury or damage to the machine from airborne objects.

### 8. Before switching the machine 'ON'

- Clear the machine table of all objects (tools, scrap pieces etc.)
- Make sure there is no debris between the work piece and the table / work support.
- Ensure that the work piece is not pressed against, or touching the saw blade or cutting tool.
- Check all clamps, work holding devices and fences to ensure that they are secure and cannot move during machining operations.
- Plan the way that you will hold and feed the work piece for the entire machining operation.

### 9. Whilst machining

- Before starting work, watch the machine while it runs. If it makes an unfamiliar noise or vibrates excessively, switch the machine 'OFF' immediately and disconnect it from the power supply. Do not restart until finding and correcting the source of the problem.

### 10. Keep the work area clear

- Working clearances can be thought of as the distances between machines and obstacles that allow safe operation of every machine without limitation. Consider existing and anticipated machine needs, size of material to be processed through each machine and space for auxiliary stands and/or work tables. Also consider the relative position of each machine to one another for efficient material handling. Be sure to allow yourself sufficient room to safely operate your machines in any foreseeable operation.
- Cluttered work areas and benches create the risk of accidents. Keep benches clear and tidy away tools that are not in use.
- Ensure that the floor area is kept clean and clear of any dust and debris that may create trip or slip hazards.

### 11. Consider the work area environment

- Do not expose the machine to rain or damp conditions.

- Keep the work area well lit and ensure that there is artificial lighting available when there is insufficient natural light to effectively light the work area. Lighting should be bright enough to eliminate shadow and prevent eye strain.
- Do not use the machine in explosive environments eg. in the presence of flammable liquids, gases or dust.
- The presence of high levels of dust created by machining wood can present a risk of fire or explosion. Always use dust extraction equipment to minimise the risk.

### 12. Keep other persons away (and pets)

- The machine is designed to be used by one person only.
- Do not let persons, especially children, touch the machine or extension cable (if used) and keep visitors away from the work area.
- Never leave the machine running unattended. Turn the power supply off and do not leave the machine unattended until it comes to a complete stop.
- If the work area is to be left unattended, all machinery should be switched 'OFF' and isolated from the mains power supply.

### 13. Store machines safely when not in use

- When not in use, machines should be stored in a dry place, out of reach of children. Do not allow persons unfamiliar with these instructions or with the machine to operate it.

### 14. Do not overreach

- Choose a working position that allows your body to remain balanced and feed the work piece in to the machine without overreaching.
- Keep proper footing and balance at all times.

### 15. Electrical supply

- Electrical circuits should be dedicated to each machine or large enough to handle combined motor amp loads. Power outlets should be located near each machine so that power or extension cables are not obstructing high-traffic areas. Observe local electrical guidelines for proper installation of new lighting, power outlets, or circuits.
- The machine must be connected to an earthed power supply.
- The power supply must be equipped with a circuit breaker that provides short circuit, overload and earth leakage protection.
- The voltage of the machine must correspond to the voltage of the mains power supply.
- The mains plug fitted to the machine should always match the power outlet. Do not modify the plug in any way. If a replacement plug is required it should be fitted by a competent person and of the correct type and rating for the machine.
- If you are unsure about any electrical connections always consult a qualified electrician.

### 16. Avoid unintentional starting of the machine

- Most machines are fitted with a no-volt release (NVR) switch to prevent unintentional starting. If in doubt always ensure the machine switch is in the 'OFF' position before connecting it to the power supply. This means the machine will not automatically start up after a power cut or switching on of the power supply, unless you first reset the start switch.

### 17. Outdoor use

- Your machine should not be used outdoors.

### 18. Extension cables

- Whenever possible, the use of extension cables is not recommended. If the use of an extension cable is unavoidable, then it should have a minimum core cross section of 2.5 mm<sup>2</sup> and limited to a maximum length of 3 metres.
- Extension cables should be routed away from the direct working area to prevent a trip hazard.

### 19. Guard against electric shock

- Avoid body contact with earthed or grounded surfaces such as pipes and radiators. There is an increased risk of electric shock if your body is earthed or grounded.

### 20. Always work within the machine's intended capacities

- Operator safety and machine performance are seriously adversely

## 2. General Health & Safety Guidance cont.

affected if attempts to make the machine perform beyond its limits are made.

### 21. Do not abuse the power cable

- Never pull the power cable to disconnect it from the power socket. Always use the plug.
- Keep the power cable away from heat, oil and sharp edges.
- Do not use the power cable for carrying or moving the machine.

### 22. Secure the work piece

- Ensure that the work piece is securely held before starting to machine it.
- When working within 300 mm of the machining area, always use a push stick to feed the work piece in to the blade or cutting tool. The push stick should have a minimum length of 400 mm. If the push stick becomes damaged, replace it immediately.
- Use extra supports (roller support stands etc.) for any work pieces large enough to tip when not held down to the table top.
- Do not use another person as a substitute for a table extension, or as additional support for a work piece that is longer or wider than the basic table, or to help feed, support, or pull the work piece.
- Do not attempt to machine more than one work piece at a time.
- When feeding the work piece towards the blade or cutting tool never position your hands in direct line of the cutting path. Avoid awkward operations and hand positions where a sudden slip could cause your hand or fingers to move into the machining area.

### 23. Stay alert

- Safety is a combination of operator common sense and alertness at all times when the machine is being used.
- Use all machines with extreme care and do not use the machine when you are tired or under the influence of drugs, alcohol or medication.

### 24. Use the correct tool for the job

- Do not use the machine for any purpose other than which it was designed.
- When selecting replacement cutting tools and blades, always ensure that they are designed to cut the material that you intend to use them for. If in any doubt seek further advice from the manufacturer.

### 25. Connect dust extraction equipment

- Always use dust extraction equipment. The dust extractor should be of suitable size and capacity for the machine that it is connected to and have a filtration level appropriate to the type of waste being collected. Refer to the relevant section of the manual for details of the specific dust extraction requirements for this machine.
- The dust extractor should be switched 'ON' before starting the machine that it is connected to. The dust extractor should be left running for 30 seconds after the last machining operation is complete in order to clear any residual waste from the machine.

### 26. Ensure that the machine is correctly guarded

- Never use the machine if any of the standard safety guards and equipment are removed or damaged.
- Some machines incorporate safety interlocks to prevent the machine from being used without the guards in place. Never attempt to bypass or modify the interlocks to allow the machine to be used without the guards in place.

### 27. Maintain your machine with care

- This manual gives clear instructions on installation, set up and operation of the machine and also details any routine and preventative maintenance that should be performed periodically by the user.
- Remember always to switch off and unplug the machine from the power supply before carrying out any setting up or maintenance operations.
- Follow any instructions for the maintenance of accessories and consumables.
- Do not use compressed air to clean the machine. Always use a brush to dislodge dust in places that are awkward to reach and a dust extractor to collect the waste.
- Inspect electric cables periodically and, if damaged, have them replaced by an authorised service facility or qualified electrician.
- Inspect extension cables (if used) periodically and replace if damaged.

### 28. Keep cutting tools sharp and clean

- Correctly maintained cutting tools are easier to control and less likely to bind.
- Cutting tools and blades can become hot during use. Take extreme care when handling them and always allow them to cool before changing, adjusting or sharpening them.

### 29. Disconnect the machine from the power supply

- When not in use, before servicing, changing blades etc. always disconnect the machine from the power supply.

### 30. Check for damaged parts

- Before each use of the machine, it should be carefully checked to determine that it will operate properly and perform its intended function.
- Check for alignment of moving parts, binding of moving parts, breakage of parts and any other conditions that may affect the operation of the machine.
- A guard or other part that is damaged should be properly repaired or replaced by a qualified person unless otherwise indicated in this instruction manual.
- Do not use the machine if the switch does not turn the machine 'ON' and 'OFF'.
- Have defective switches replaced by a qualified person.

### 31. Warning!

- The use of any accessory or attachment, other than those recommended in this instruction manual, or recommended by our Company may present a risk of personal injury or damage to the machine and invalidation of the warranty.

### 32. Have your machine repaired by a qualified person

- This machine complies with the relevant safety rules and standards appropriate to its type when used in accordance with these instructions and with all of the standard safety guards and equipment in place. Only qualified persons using original spare parts should carry out repairs. Failure to do this may result in considerable danger to the user and invalidation of warranty.

### 33. Caution! Motor may become hot during use

- It is normal for motors on some machines to become hot to the touch during use. Avoid touching the motor directly when in use.



**WARNING:** This product is heavy and as a precaution it is advised that two people assemble the machine.

# 3. Record Power Guarantee

**"Products"** means the Products sold by Record Power subject to these terms and conditions;

**"Record Power"** is Record Power Limited, whose company registration number is 4804158 and registered office address is Centenary House, 11 Midland Way, Barlborough Links, Chesterfield, Derbyshire, S43 4XA and sells through a network of Authorised Dealers;

**"Authorised Distributor"** is the nominated importer for your region who will generally sell through a network of Authorised Dealers. Details of Authorised Distributors for specific countries can be found in the Product manual or at [www.recordpower.info](http://www.recordpower.info);

**"Authorised Dealer"** is a retailer or business authorised to sell Record Power Products to end users.

## 1 Guarantee

- 1.1 Record Power guarantees that for a period of 5 years from the date of purchase the components of qualifying Products (see clauses 1.2.1 to 1.2.9) will be free from defects caused by faulty construction or manufacture.
- 1.2 During this period Record Power, its Authorised Distributor or Authorised Dealer will repair or replace free of charge any parts which are proved to be faulty in accordance with paragraphs 1.1 above provided that:
  - 1.2.1 you follow the claims procedure set out in clause 2 below;
  - 1.2.2 Record Power, our Authorised Distributor or Authorised Dealer are given a reasonable opportunity after receiving notice of the claim to examine the Product;
  - 1.2.3 if asked to do so by Record Power, its Authorised Distributor or Authorised Dealer, you return the Product, at your own cost, to Record Power's premises or other approved premises such as those of the Authorised Distributor or supplying Authorised Dealer, for the examination to take place;
  - 1.2.4 the fault in question is not caused by industrial use, accidental damage, fair wear and tear, wilful damage, neglect, incorrect electrical connection, abnormal working conditions, failure to follow our instructions, misuse, or alteration or repair of the Product without our approval;
  - 1.2.5 the Product has been used in a domestic environment only;
  - 1.2.6 the fault does not relate to consumable Products such as blades, bearings, drive belts or other wearing parts which can reasonably be expected to wear at different rates depending on usage (for full details contact Record Power or your local Authorised Distributor);
  - 1.2.7 the Product has not been used for hire purposes, by you or by a previous owner;
  - 1.2.8 the Product has been purchased by you as the guarantee is not transferable from a private sale.
  - 1.2.9 where the Product has been purchased from a retailer, the 5 year guarantee is transferable and begins on the date of the first purchase of the Product and in the event of a claim under this guarantee proof of the original purchase date will be required to validate the warranty period.

## 2 Claims Procedure

- 2.1 In the first instance please contact the Authorised Dealer who supplied the Product to you. In our experience many initial problems with machines that are thought to be due to faulty parts are actually solved by correct setting up or adjustment of the machines. A good Authorised Dealer should be able to resolve the majority of these issues much more quickly than processing a claim under the guarantee.
- 2.2 Any damage to the Product resulting in a potential claim under the guarantee must be reported to the Authorised Dealer from which it was purchased within 48 hours of receipt.
- 2.3 If the Authorised Dealer who supplied the Product to you has been unable to satisfy your query, any claim made under this Guarantee should be made directly to Record Power or its Authorised Distributor (for details of the Authorised Distributor in your country please see your Product manual or check [www.recordpower.info](http://www.recordpower.info) for details). The claim itself should be made in a letter setting out the date and place of purchase, and giving a brief explanation of the problem which has led to the claim. This letter should then be sent with proof of the purchase date (preferably a receipt) to Record Power or its Authorised Distributor. If you include a phone number or email address this will help to speed up your claim.
- 2.4 Please note that it is essential that the letter of claim reaches Record Power or its Authorised Distributor on the last day of this Guarantee at the latest. Late claims will not be considered.

## 3 Limitation of Liability

- 3.1 We only supply Products for domestic and private use. You agree not to use the Product for any commercial, business or re-sale purposes and we have no liability to you for any loss of profit, loss of business, business interruption or loss of business opportunity.
- 3.2 This Guarantee does not confer any rights other than those expressly set out above and does not cover any claims for consequential loss or damage. This Guarantee is offered as an extra benefit and does not affect your statutory rights as a consumer.

## 4 Notice

This Guarantee applies to all Products purchased from an Authorised Dealer of Record Power within the United Kingdom of Great Britain and Northern Ireland. Terms of Guarantee may vary in other countries – please check with the Authorised Distributor in your country (details of the Authorised Distributor for your country can be found in the manual or at [www.recordpower.info](http://www.recordpower.info)).

# 4. Specifications

## DP58P

**Throat Depth:** 190 mm  
**Depth of Feed:** 80 mm  
**Chuck to Table:** 668 mm  
**Chuck to Base:** 1154 mm  
**Motor:** 230 V / 50 Hz / 800 W input  
**Chuck:** 2 Morse Taper / 16 mm  
**Speeds:**  
 180, 250, 300, 400, 480, 580, 970, 1280, 1410, 1540, 2270, 2740 rpm  
**Weight:** 67 kg  
**Full Load Current:** 3.6A  
**Sound Power Level:** <83dB (A)  
**Sound Pressure Level:** <83dB (A)

## DP58B

**Throat Depth:** 165 mm  
**Depth of Feed:** 80 mm  
**Chuck to Table:** 371 mm  
**Chuck to Base:** 548 mm  
**Motor:** 230 V / 50 Hz / 560 W input  
**Chuck:** 2 Morse Taper / 16 mm  
**Speeds:**  
 180, 250, 300, 400, 480, 580, 970, 1280, 1410, 1540, 2270, 2740 rpm  
**Weight:** 55 kg  
**Full Load Current:** 2.6A  
**Sound Power Level:** <83dB (A)  
**Sound Pressure Level:** <83dB (A)

# 5. Contents of the Package

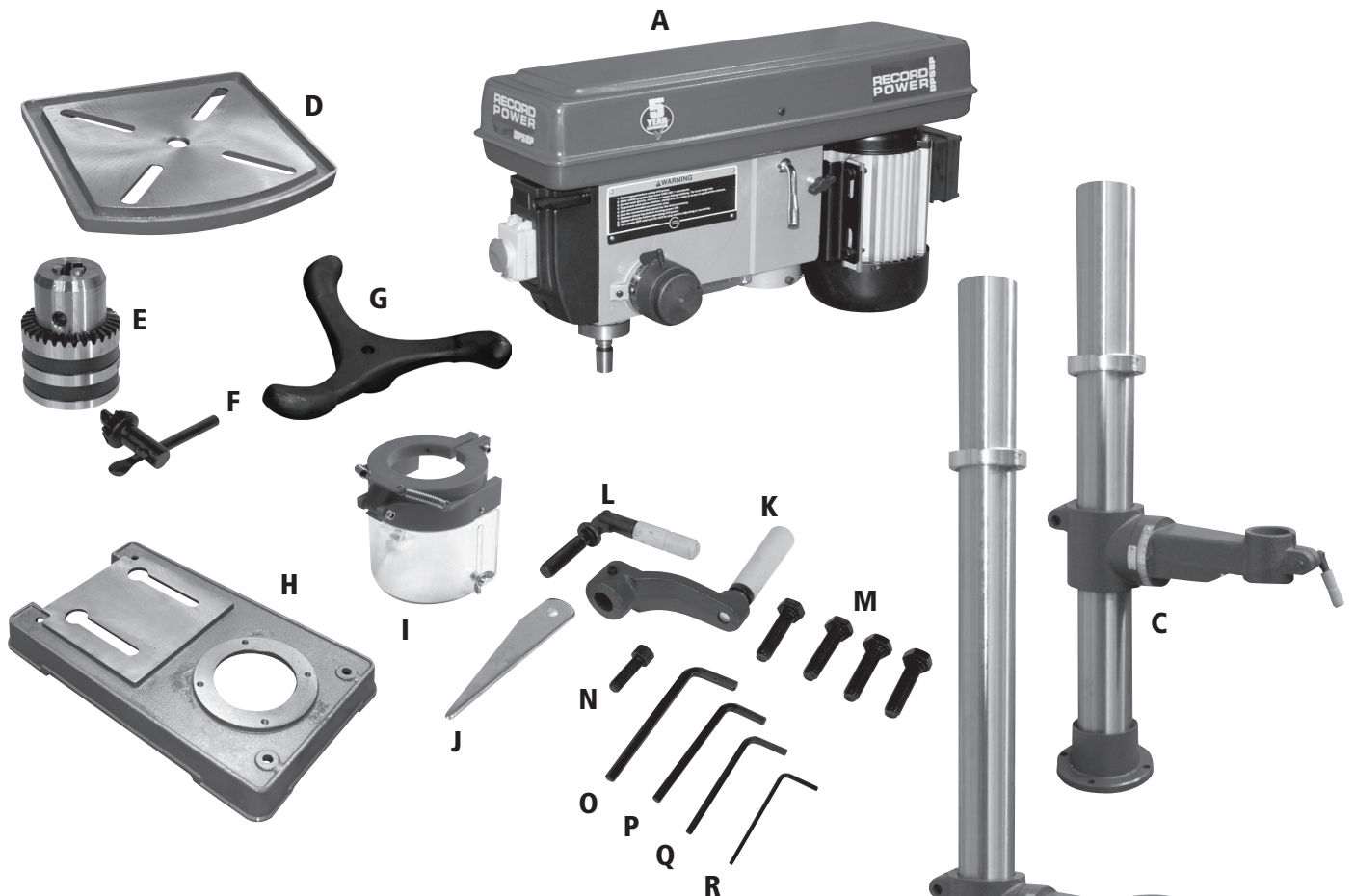

- A Head
- B Column, table support and rack (DP58P)
- C Column, table support and rack (DP58B)
- D Table
- E Chuck
- F Chuck key
- G Feed handle
- H Base
- I Chuck guard

- J Drift key
- K Table support locking handle
- L Table crank handle
- M M10 hex head bolts x 4
- N M5 Hex head socket bolt
- O M5 hex wrench
- P M4 hex wrench
- Q M3 hex wrench
- R M2 hex wrench

Separate all parts from packaging materials and check each item, ensuring all items are accounted for.

Remove the protective oil that is applied to the table, column and any other parts of the machine with ordinary household type grease or spot remover.

Apply a coat of paste wax to the table and column to prevent rust. Wipe all parts thoroughly with a clean, dry cloth.

# 6. Getting To Know Your Drilling Machine

DP58P shown.

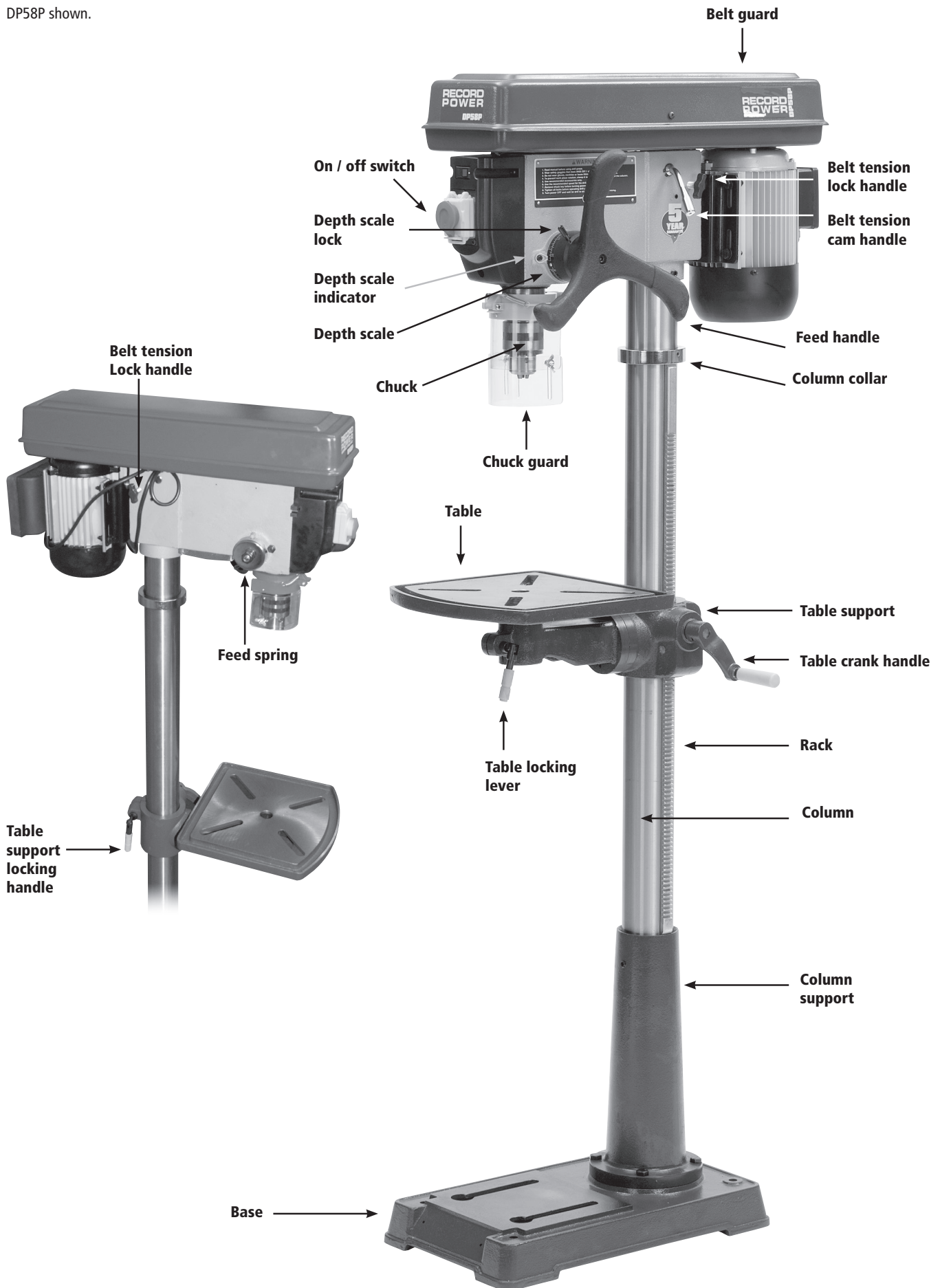

# 7. Assembly



**Caution: Many of the items are very heavy. We recommend that assistance is sought before trying to lift the larger components.**

The column, column support and rack are supplied preassembled. To secure to the base, align the four holes in the support casting with the corresponding holes in the base and secure using four M10 x 20 mm hex head screws (**Fig. 7.1**). The rack should be positioned to the right of the column (looking from the front of the machine) to ensure the table will be at the front of the machine when fitted.

Fit the table locking handle to the rear of the table support. Note that one side of the table support has a plain bore and the other a tapped hole. Ensure that the locking handle is passed through the plain bore and into the tapped hole in order for the table support to clamp correctly around the column (**Fig 7.2**).

Fit the table crank handle to the shaft protruding from the table support and secure using the M6 x 8 mm blind set screw (**Fig. 7.3**).

Attach the table to the table support by placing the column on the underside of the table through the hole at the front of the table support (**Fig. 7.4**). Secure in place by tightening the table locking lever.

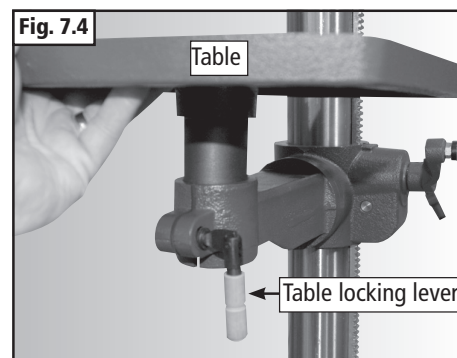
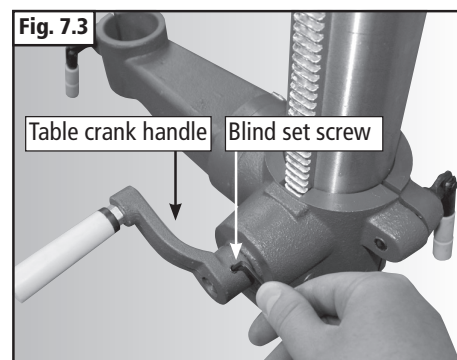
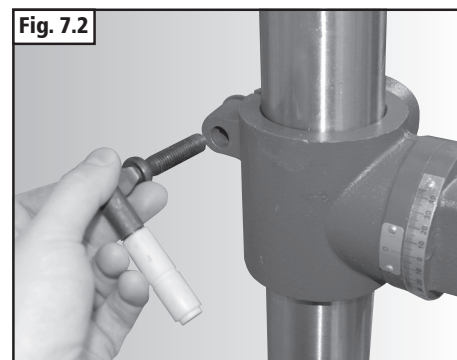
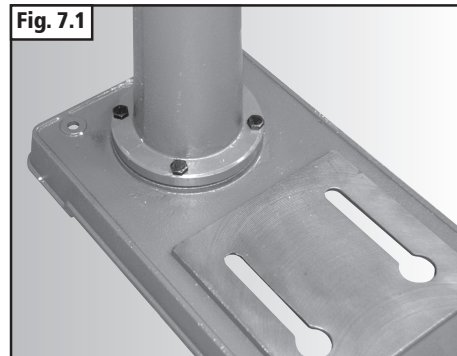



## 7. Assembly - Cont.

Attach the head assembly of the drill to the top of the column and secure using both the M10 x 12 mm blind set screws which are pre-installed to the collar of the head assembly (**Fig. 7.5**). Before placing the head assembly onto the column, ensure that the blind set screws do not protrude into the inside of the head assembly. Before fully tightening the screws check that the head is correctly aligned with the base so that the spindle is above the centre line of the base casting.

To attach the feed handle to the head assembly, align the roll pin on the inside of the handle collar (**Fig. 7.6**) with the slot in the rise and fall pinion shaft (**Fig. 7.7**) and secure in place using the M8 x 25 mm socket head cap screw (**Fig. 7.8**).

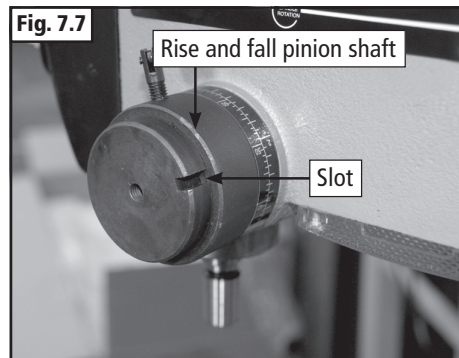
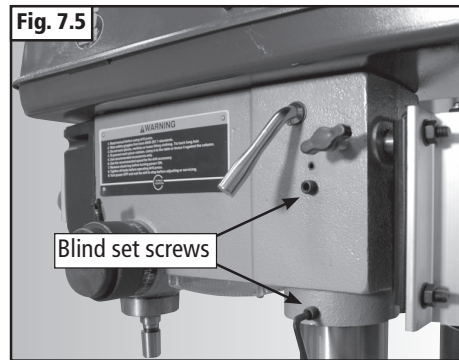

## 7. Assembly - Cont.

The chuck can now be fitted to the arbor. Before fitting the chuck, both the taper of the arbor and the corresponding taper in the rear of the chuck should be thoroughly cleaned to remove any foreign bodies that may prevent the chuck from seating correctly. Clean both surfaces with white spirit to remove any heavy deposits of grease and dirt and then apply a thin coat of silicon spray or similar to both tapers before assembling. Once the chuck is in position, tap it firmly and squarely with a soft faced mallet to ensure it is fully seated on to the spindle (**Fig. 7.9**).

To fit the chuck guard, place it onto the collar of the spindle sleeve (**Fig. 7.9**), ensuring the transparent guard is positioned at the front. Tighten the pre-installed M5 x 20 mm pan head screw to the nylon locking nut at the rear of the chuck guard (**Fig 7.10**).

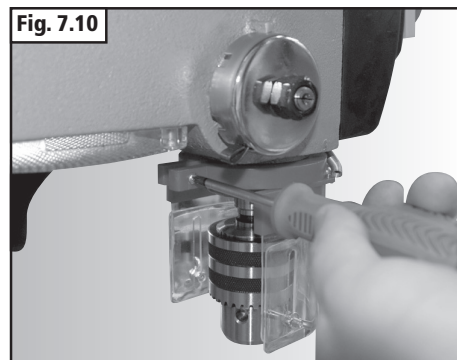
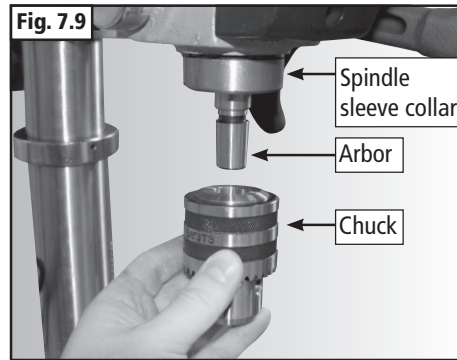

## 8. Operation

### Adjusting the Height of the Work Table

Loosen the table support locking handle then use the table crank handle to raise or lower the table to the desired height allowing clearance for the drill bit above the work piece. To secure the table, tighten the table support locking handle (**Fig. 8.1**).

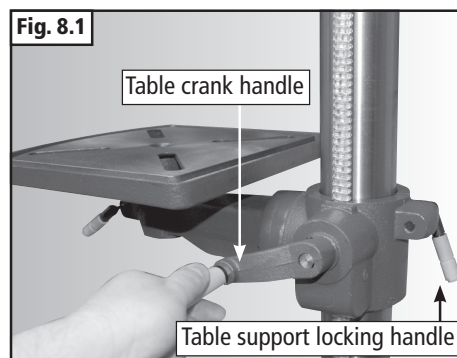

# 8. Operation - cont.

## Using the Base as a Work Table

If the size of the work piece is too large to be accommodated using the work table, it can be swung away from the chuck so that the base can be used to support the work piece (**Fig. 8.2**). To do this, unscrew the table support locking handle and rotate the table around the column of the machine. It may be necessary to loosen the blind set screw on the column collar slightly to allow the rack to move freely around the column with the table (**Fig. 8.3**).

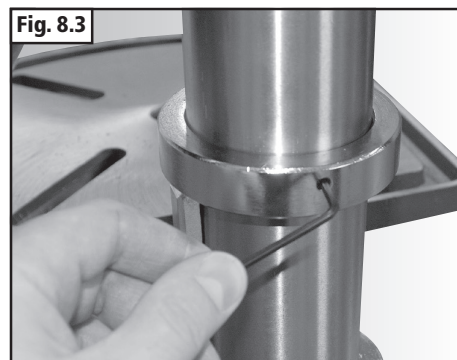

## Tilting the Table

The table can be tilted in order to drill at an angle into the work piece. Loosen the locking bolt on the underside of the table support (**Fig. 8.4**) and using the angle indication scale as a reference (**Fig. 8.5**), tilt the table to the desired angle and re-tighten the locking bolt.

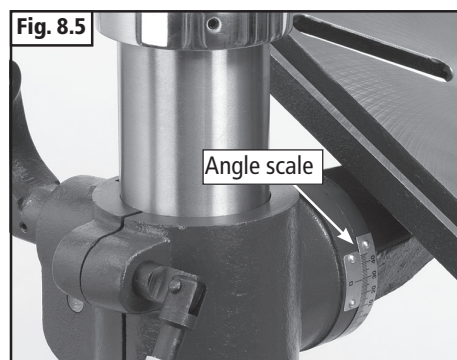
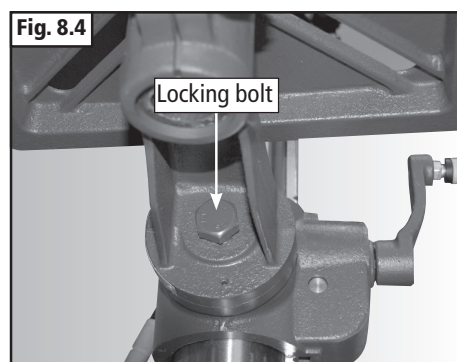

## 8. Operation - cont.

### Using the Depth Stop

The machine features a depth stop on the right hand side of the head assembly (**Fig. 8.6**).

To set the machine to control the depth of the chuck movement, firstly ensure the chuck spindle is fully retracted by turning the feed handle clockwise as far as it will go. Loosen the depth scale lock (**Fig. 8.6**) and rotate the depth scale to the desired depth, in this case 20 mm, by aligning it with the depth scale indicator (**Fig. 8.7**) and tightening the depth scale lock. The depth is now set to 20 mm and by turning the feed handle anti-clockwise to lower the chuck, it will only travel 20 mm downwards.

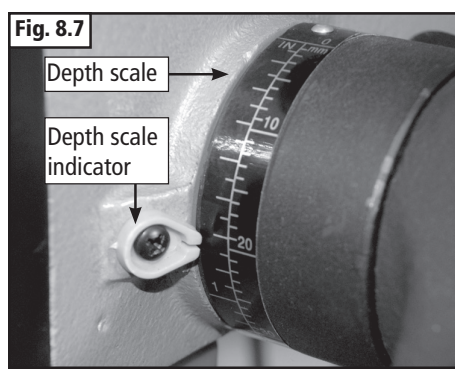
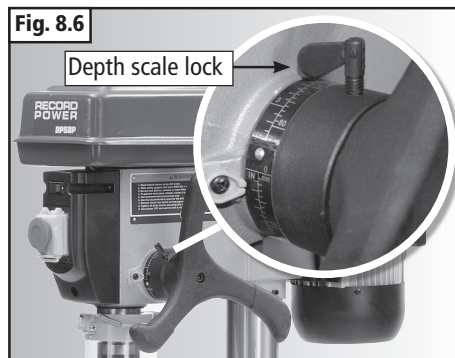

### In the Event of a Blockage or if the Machine Stalls

If the machine stalls during use, the most likely cause is excessive pressure being applied to the feed hand wheel. Simply reducing the pressure will usually allow the drill bit to return to full speed.

In the event that the machine stalls due to a blockage that prevents the drill bit from rotating, immediately switch the machine off by pressing the red button marked 'O' on the switch.

Locate and rectify the source of the blockage and check that there is sufficient tension on the drive belt. Rotate the chuck by hand to ensure free rotation of the drill bit.

To re-start the machine press the green button marked 'I' on the switch.

### In the Event of a Power Failure

The drilling machine is fitted with a no volt release (NVR) switch to protect the user against automatic starting of the machine when power is restored after a power failure.

In the event of a power failure, first locate and rectify the source of the failure. If the fault is within the power circuit of the workshop, there may be an underlying cause (circuit overload etc.) that should be investigated by a qualified electrician, before attempting to restore the power source.

Once the power is restored, the machine can be re-started by pressing the green button marked 'I' on the switch.

# 9. Adjustments & Maintenance

## Checking the Belt Tension

Before attempting to use the machine, check that the correct speed is selected in relation to the size and type of drill bit and type of material being machined. It is important to apply the correct level of tension. Over-tensioning the belt will apply excessive load to the motor and spindle bearings and may cause damage to the machine. Insufficient tensioning of the belt will cause the machine to be noisy as there will be excess movement of the belt as it runs between the pulleys and the spindle may stall when machining as pressure is applied to the work piece. Periodically check the belt tension to maintain optimum performance of the machine.



**Before attempting any maintenance or adjustment ALWAYS ensure that the machine is disconnected from the power supply.**

## Changing the Speed Setting

1. Remove the locking screw from the belt guard, (**Fig 9.1**).
2. Unscrew the belt tension locking handles (**Fig 9.1**) located at each side of the head unit.
3. Use the belt tension cam handle to release tension on the drive belt by turning it anti-clockwise.
4. Re-position the drive belts (**Fig. 9.2**) to correspond with the appropriate speed as shown on the speed chart inside the belt guard (**Fig. 9.3**).
5. Reapply tension to the drive belt by turning the belt tension cam handle clockwise. Whilst holding the belt tension cam handle to maintain tension, tighten the tension locking handles at each side of the head unit.



An indication of the correct tension is that when one of the belts is pinched with reasonable force, each side moves no more than approximately 13 mm (**Fig. 9.4**).

## Lubrication

This machine uses sealed bearing units which require no maintenance for the life of the product.

The table elevation mechanism and the splines (grooves) in the spindle pulley system may need to be lubricated periodically.

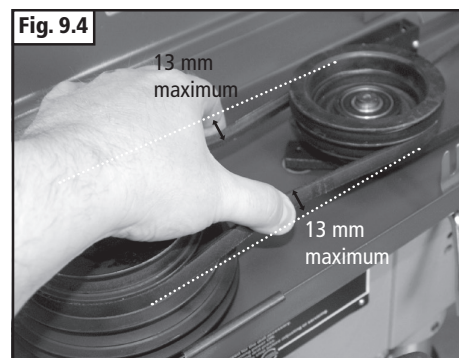
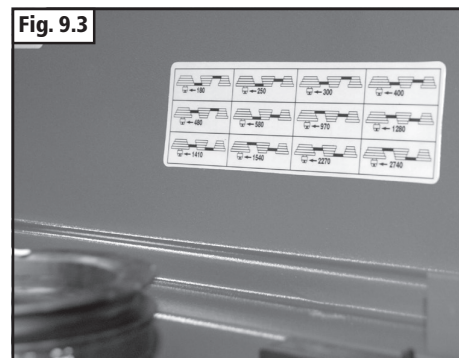
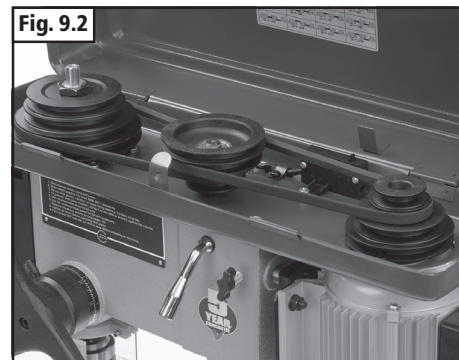
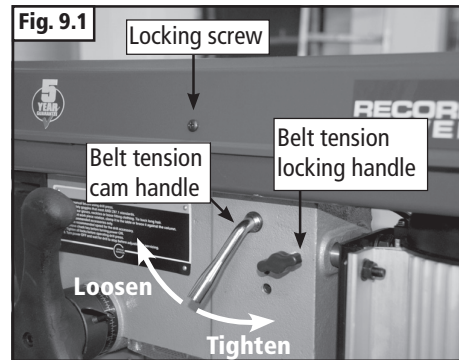

# 9. Adjustments & Maintenance - cont.

## Using Large Drill Bits

The machine will accept any drill bits with a number 2 morse taper, providing the chuck and arbor are removed first.

To remove the chuck and arbor, turn the feed handle anti-clockwise to expose the hole in the spindle sleeve then align this with the hole in the spindle and place the drift key through both holes so it is positioned above the arbor (**Fig. 9.5**). Using a soft headed mallet, tap the drift key until it forces the arbor downwards and off the spindle. To avoid possible damage, place one hand under the chuck to catch it when it becomes disengaged along with the arbor.

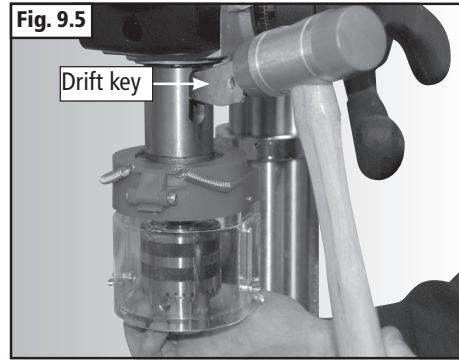

## Aligning the Table with the Chuck

To ensure the table is at 90° to the chuck from side-to-side, make sure the angle scale is set to 0° (**Fig. 9.6**).

To ensure the table is at 90° to the chuck from front to back, place a drill bit in the chuck and check the angle with an engineer's square from the side of the machine (**Fig. 9.7**). If any adjustment is required, the table angle can be changed by using the blind set screw located on the underside of the headstock (**Fig. 9.8**). Turn the screw clockwise to raise the front of the table and anti-clockwise to lower the front of the table until 90° is achieved.

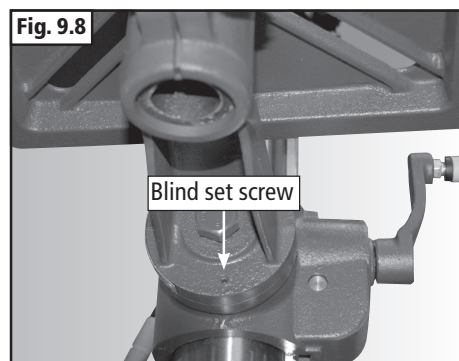
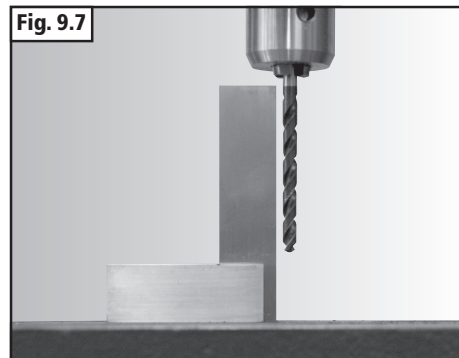
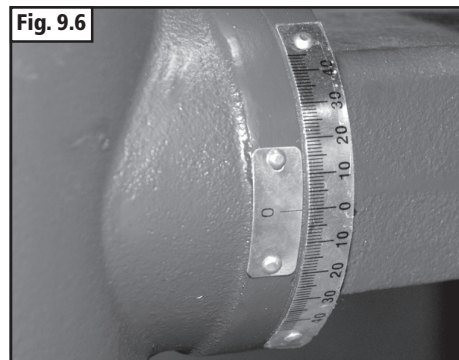

## 9. Adjustments & Maintenance - cont.

### Replacing the Headstock Spindle Return Spring

The headstock spindle return spring is located on the opposite side of the headstock to the rise and fall handle. It is pre-tensioned at the factory to the correct tension and should need no adjustment through its life.



**Warning: Unless the headstock spindle return spring is broken do not attempt to remove it. The tension of the spring can cause the spring cap to unwind with enough force to cause injury.**

In the event that a broken spring needs replacing, remove the outer nut from the threaded spindle then loosen the inner nut until the spring cap can be pulled back to release it from the notch holding it in place, **Fig. 9.9**. To release any remaining tension, turn the spring cap clockwise, taking care not to let the cap spin as the broken spring may still be under a small amount of tension. There is a loop on the side of the cap which can be held with the thumb to give a better grip.

Once the cap is loose, remove the inner nut and take the cap and spring from the threaded spindle.

Take the new cap and spring and place onto the threaded spindle, **Fig. 9.10**, ensuring the central straight piece of the spring is inserted into the slot on the threaded spindle, **Fig. 9.11**.

With the headstock spindle in its lowest position, carefully rotate the cap anti-clockwise to apply tension to the spring. When enough tension has been applied to retract the headstock spindle fully (to its highest position) secure it onto the notch protruding from the headstock with the closest notch on the cap and refit the inner nut to ensure the cap is fixed in place whilst also allowing it to rotate freely as the spindle is raised and lowered. Refit the outer nut and tighten to ensure the inner nut is secured in place, **Fig. 9.12**.

Use the rise and fall handle to pull down the spindle and test the tension of the spring. If the spindle returns to its original position unaided then the spring is at the correct tension. If not, more tension needs to be applied. If the spindle returns with excessive force then the tension should be reduced. Only enough tension need be applied to return the spindle gently to its original position.

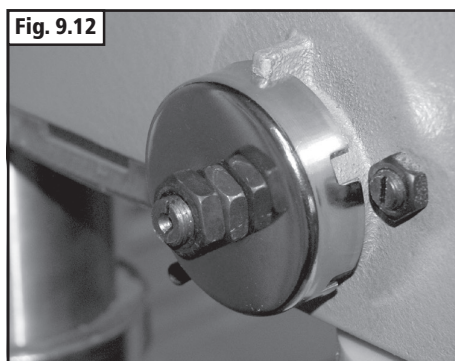
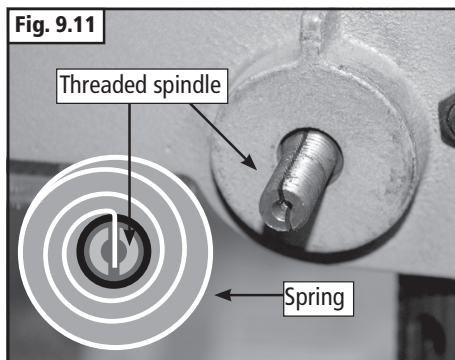
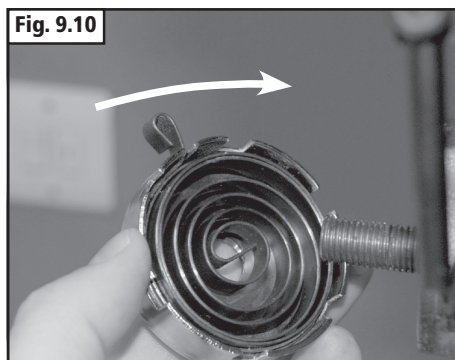
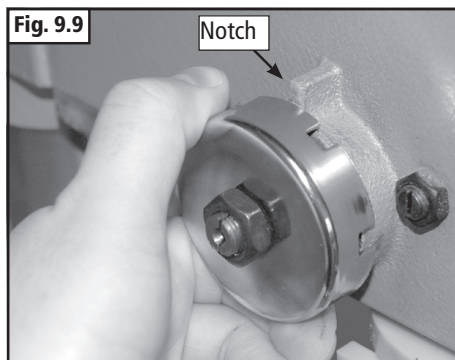

# 10. Electrical Connection & Wiring Diagram

Machines supplied for use in the UK are fitted with a 3 pin plug conforming to BS1363, fitted with a fuse conforming to BS1362 and appropriate to the current rating of the machine.

Machines supplied for use in other countries within the European Union are fitted with a 2 pin Schuko plug conforming to CEE 7/7.

Machines supplied for use in Australia & New Zealand are fitted with a 3 pin plug conforming to AS/NZS3112.

In all cases, if the original plug or connector has to be replaced for any reason, the wires within the mains power cable are colour coded as follows:

## 230 V (Single Phase)

Brown: Live (L)  
 Blue: Neutral (N)  
 Green and Yellow: Earth (E)

The wire coloured brown must always be connected to the terminal marked 'L' or coloured red.

The wire coloured blue must always be connected to the terminal marked 'N' or coloured black.

The wire coloured green and yellow must always be connected to the terminal marked 'E' or with the earth symbol:



or coloured green / green and yellow.

It is important that the machine is effectively earthed. Some machines will be clearly marked with the double insulated logo:



In this case there will not be an earth wire within the circuit.

In the case of the BS1363 plug for use in the UK, always ensure that it is fitted with a fuse conforming to BS1362 appropriate to the rating of the

machine. If replacing the original fuse, always fit a fuse of equivalent rating to the original. Never fit a fuse of a higher rating than the original. Never modify the fuse or fuse holder to accept fuses of a different type or size.

Where the current rating of the machine exceeds 13 A at 230 V, or if the machine is designated for use on a 400 V 3 phase supply a connector conforming to BS4343 (CEE17 / IEC60309) will be used.

230 V machines will be fitted with a blue 3 pin connector. The wiring for this type of this connector will be the same as shown above.

400 V, 3 phase machines will be fitted with a red 4 or 5 pin connector. The wiring for this type of connector is as shown below:

## 400 V (3 phase)

Brown: Live (L1)  
 Black: Live (L2)  
 Grey: Live (L3)  
 Blue: Neutral (N)  
 Green and Yellow: Earth (E)

The wire coloured brown must always be connected to the terminal marked 'L1'.

The wire coloured black must always be fitted to the terminal marked 'L2'.

The wire coloured grey must always be connected to the terminal marked 'L3'.

The wire coloured blue must always be connected to the terminal marked 'N' or coloured black.

The wire coloured green and yellow must always be connected to the terminal marked 'E' or with the earth symbol

If in doubt about the connection of the electrical supply, always consult a qualified electrician.

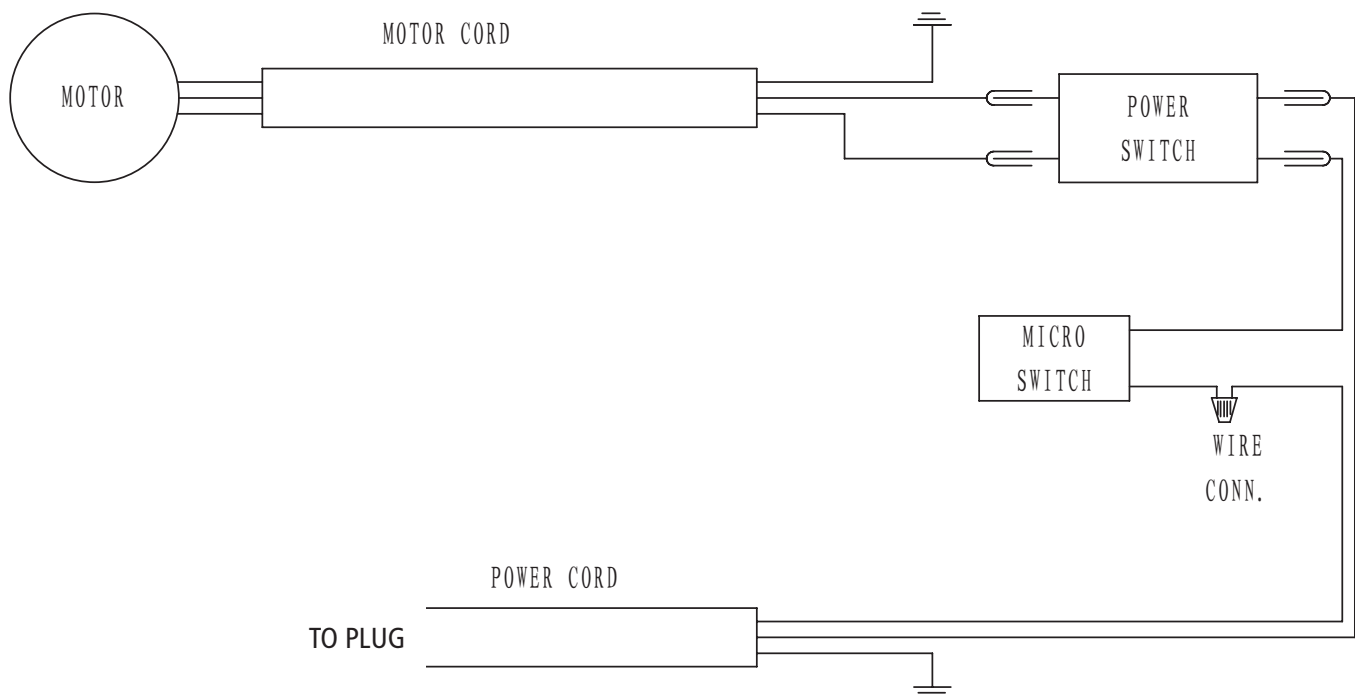



# 11. Dust Extraction

## The Importance Of Dust Extraction

Before the machine is started, ensure that adequate dust extraction provisions have been installed. Dust extraction is extremely important not only for health and safety but also for the correct upkeep of the machine. Saw dust can cause the machine not to operate properly or even fail completely. By keeping the machine free of large amounts of waste the performance will be optimised.

If a large amounts of MDF or toxic woods are to be cut we recommend that there is a good ventilation system in place and that in addition to proper extraction a mask or respirator be worn as minimum protection.

## Record Power Extractors

Record Power offer a range of high quality dust extractors, we offer both drum and bag type extractors which filter down 0.5 micron providing protection from harmful fine dusts. All Record Power dust extractors & chip collectors have 100 mm inlets and hoses.

### DX1000 High Filtration Dust Extractor

Drum type extractor, 45 litre capacity, single 1 kW motor, suitable for intermittent use ie must be switched off for 20 minutes every hour.  
**0.5 micron filtration**

### RSDE1 High Filtration Dust Extractor

Drum type extractor, 45 litre capacity, single 1 kW motor, suitable for intermittent use ie must be switched off for 20 minutes every hour.  
**0.5 micron filtration**

### RSDE2 High Filtration Dust Extractor

Drum type extractor, 50 litre capacity, single 1 kW motor, suitable for intermittent use ie must be switched off for 20 minutes every hour.  
**0.5 micron filtration**

### RSDE/2A High Filtration Dust Extractor with Auto Switching

Drum type extractor, 50 litre capacity, single 1 kW motor, auto switching allows the machine to be turned on and off as machines and power tools are operated. Suitable for intermittent use ie must be switched off for 20 minutes every hour. Maximum auto switch capacity tools up to 1.1 kW.  
**0.5 micron filtration**

### DX4000 High Filtration Dust Extractor

Drum type extractor, 80 litre capacity, Twin 1 kW motor, suitable for heavy usage ie if one motor is switched off for 20 minutes then the other can be used thus enabling continuous usage. Or both motors can be used simultaneously giving maximum suction but in this mode the extractor must be switched off for 20 minutes every hour. **0.5 micron filtration**

### DX5000 High Filtration Dust Extractor

Bag type extractor, 200 litre capacity, Twin 1 kW motor, suitable for heavy usage ie if one motor is switched off for 20 minutes then the other can be used thus enabling continuous usage. Or both motors can be used simultaneously giving maximum suction but in this mode the extractor must be switched off for 20 minutes every hour. **0.5 micron filtration**

### CX2000 Compact Chip Extractor

Medium capacity chip collector, with a powerful 0.56 kW induction motor. An extremely smooth running unit suitable for continuous usage. Very quiet impeller system extracts dust and chippings.

### CX2600 Chip Collector

Large capacity chip collector, with a powerful 0.37 kW induction motor. An extremely smooth running unit suitable for continuous usage. Very quiet impeller system extracts dust and chippings.

**Suitable for chip collection or finer dust using the optional filter cartridge**

### CX3000 Chip Collector

Larger capacity chip collector, with a more powerful 0.75 kW induction motor and heavy duty construction. An extremely smooth running unit suitable for continuous usage. Very quiet impeller system extracts dust and chippings.

**Suitable for chip collection or finer dust using the optional filter cartridge**

### Air Cleaners

It is strongly advised to also use an air cleaner to remove the fine airborne dust present in the workshop which cannot be removed using machine extraction. Record Power offer a range of air cleaners suitable for all home workshops. Please contact your preferred stockist or visit [www.recordpower.info](http://www.recordpower.info).

	DX1000	RSDE1	RSDE2	RSDE/2A	DX4000	DX5000	CX2000	CX2600	CX3000
<b>Bandsaws Circular saws Sanders</b> Intermittent usage	✓ Recommended	✓ Recommended	✓ Recommended	✓ Recommended	✓ Recommended	✓ Recommended			
<b>Bandsaws Circular saws Sanders</b> Heavy usage					✓ Recommended	✓ Recommended			
<b>Planer Thicknessers Spindle Moulders Universals</b> Intermittent usage	✓ Recommended	✓ Recommended			✓ Can be used	✓ Recommended	✓ Recommended	✓ Recommended	✓ Recommended
<b>Planer Thicknessers Spindle Moulders Universals</b> Heavy usage					✓ Can be used	✓ Recommended		✓ Recommended	✓ Recommended
<b>Dust Extraction System</b> Intermittent usage					✓ Can be used	✓ Recommended			

# 12. Troubleshooting

<b>Trouble</b>	<b>Probable Cause</b>	<b>Remedy</b>
Noisy operation.	<ol style="list-style-type: none"> <li>1. Incorrect belt tension.</li> <li>2. Dry spindle.</li> <li>3. Loose spindle pulley.</li> <li>4. Loose motor pulley.</li> </ol>	<ol style="list-style-type: none"> <li>1. Adjust tension.</li> <li>2. Lubricate spindle.</li> <li>3. Check tightness of retaining nut on pulley.</li> <li>4. Tighten set screws in pulleys.</li> </ol>
Drill bit burns.	<ol style="list-style-type: none"> <li>1. Incorrect speed.</li> <li>2. Shavings not coming out of hole frequently to clear shavings.</li> <li>3. Dull drill bit.</li> <li>4. Feeding too slow.</li> <li>5. Not lubricated.</li> </ol>	<ol style="list-style-type: none"> <li>1. Change speed.</li> <li>2. Retract drill bit.</li> <li>3. Re-sharpen drill bit.</li> <li>4. Increase the speed.</li> <li>5. Lubricate drill bit.</li> </ol>
Drill bit wanders (hole not round).	<ol style="list-style-type: none"> <li>1. Hard grain in wood or lengths of cutting lips and / or angles not equal</li> <li>2. Bent drill bit.</li> </ol>	<ol style="list-style-type: none"> <li>1. Re-sharpen drill bit correctly.</li> <li>2. Replace drill bit.</li> </ol>
Wood splinters on underside.	<ol style="list-style-type: none"> <li>1. No back up material under work piece.</li> </ol>	<ol style="list-style-type: none"> <li>1. Use back up material.</li> </ol>
Workpiece moves when drilling.	<ol style="list-style-type: none"> <li>1. Not supported or clamped properly.</li> </ol>	<ol style="list-style-type: none"> <li>1. Use drill press vice to support and clamp work.</li> </ol>
Drill bit binds in workpiece.	<ol style="list-style-type: none"> <li>1. Workpiece pinching drill bit or excessive feed pressure.</li> <li>2. Improper belt tension</li> </ol>	<ol style="list-style-type: none"> <li>1. Support workpiece or clamp it.</li> <li>2. Adjust belt tension.</li> </ol>
Excessive drill bit run out or wobble.	<ol style="list-style-type: none"> <li>1. Bent drill bit.</li> <li>2. Worn spindle bearings.</li> <li>3. Drill not properly installed in chuck.</li> <li>4. Chuck not properly installed.</li> </ol>	<ol style="list-style-type: none"> <li>1. Replace drill bit.</li> <li>2. Replace bearings.</li> <li>3. Install drill bit correctly.</li> <li>4. Install chuck correctly.</li> </ol>
Spindle returns too slowly or too quickly.	<ol style="list-style-type: none"> <li>1. Spring has improper tension.</li> </ol>	<ol style="list-style-type: none"> <li>1. Adjust spring tension.</li> </ol>
Spindle does not return to position.	<ol style="list-style-type: none"> <li>1. Spring is broken.</li> </ol>	<ol style="list-style-type: none"> <li>1. Replace spring.</li> </ol>
Chuck will not stay attached to spindle, it comes loose when trying to install it.	<ol style="list-style-type: none"> <li>1. Dirt, grease or oil on the tapered inside surface of the chuck or on the spindle's tapered surface.</li> </ol>	<ol style="list-style-type: none"> <li>1. Using a household detergent clean the tapered surface of the chuck and spindle to remove all dirt, grease and oil.</li> </ol>

# 13. Parts Lists & Diagrams

- 1-1. Screw-hex soc set
- 1-2. Collar rack
- 1-3. Gear rack
- 1-4. Crank
- 1-6. Table
- 1-7. Clamp table
- 1-8. Screw-hex HD M16 x 20 - 35
- 1-9. Table assembly. w/scale
- 1-10. Base
- 1-11. Support column
- 1-12. Screw-hex HD M10 x 1.5 - 40
- 1-13. Screw-hex soc set M10 x 1.5 -12
- 1-14. Tube column
- 1-15. Rack
- 1-16. Clamp column
- 1-17. Support table w/indicator
- 1-18. Worm elevation
- 1-19. Pin gear

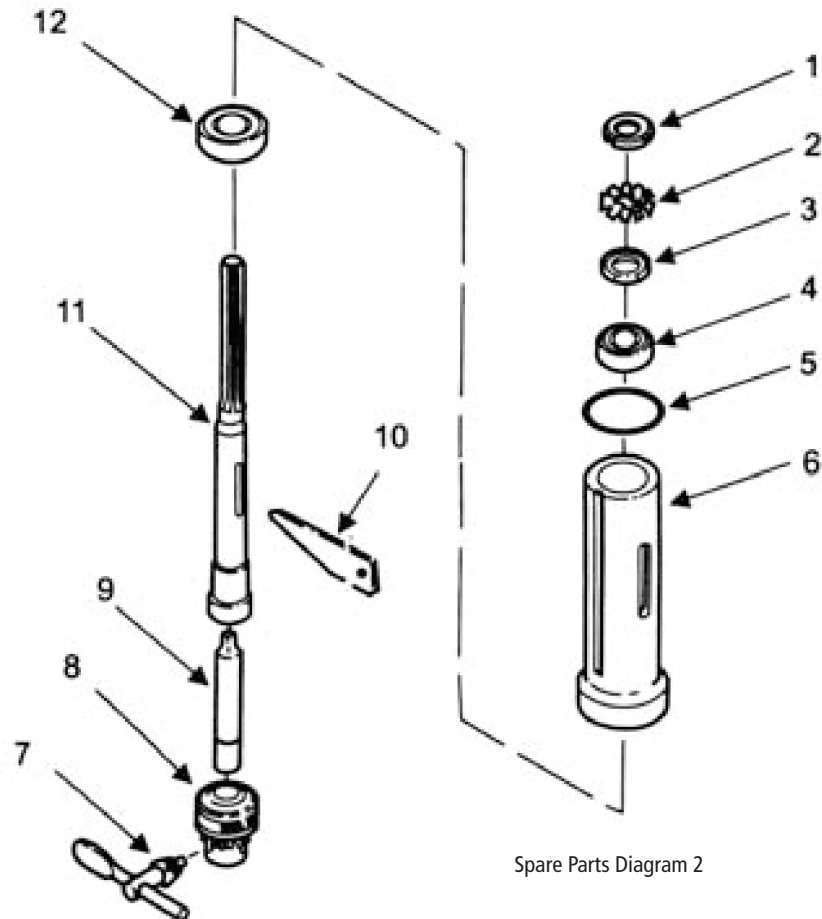
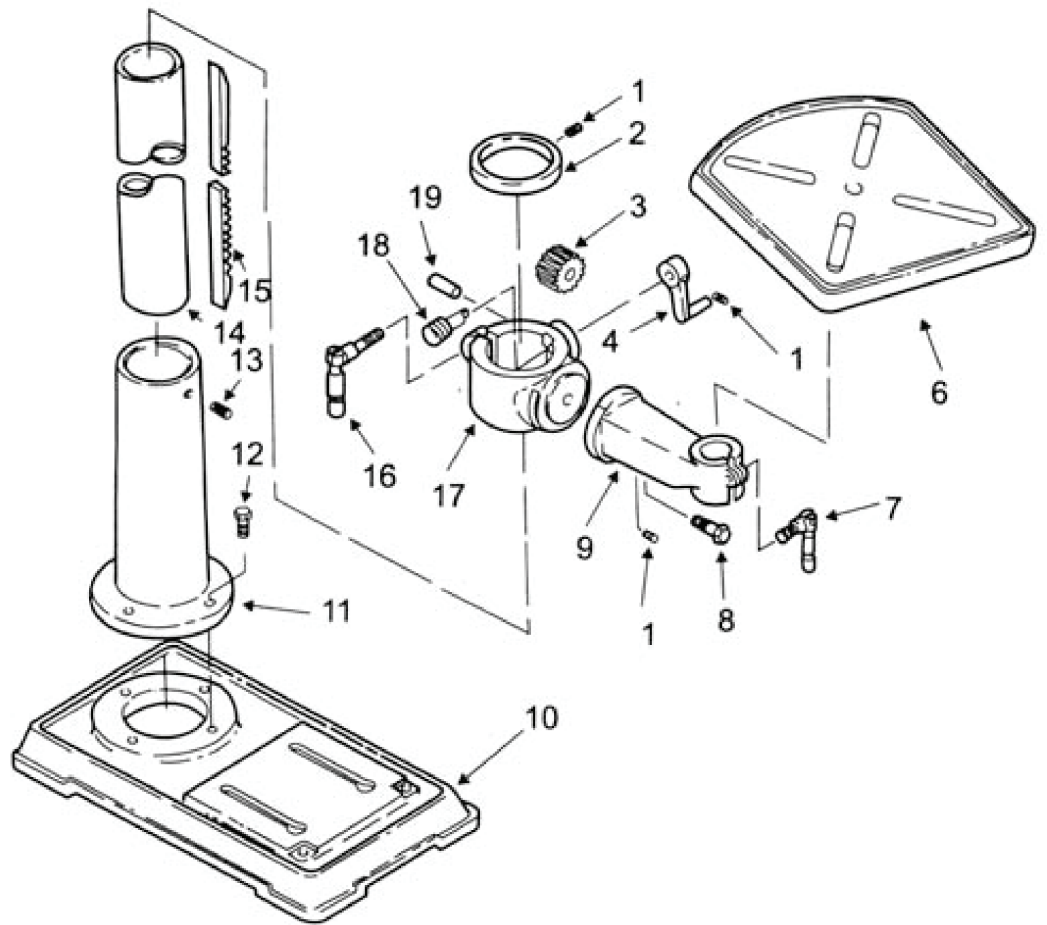

- 2-1. Nut lock
- 2-2. Locking ring
- 2-3. Washer
- 2-4. Bearing ball
- 2-5. Washer rubber
- 2-6. Spindle sleeve
- 2-7. Key chuck
- 2-8. Chuck
- 2-9. Arbor
- 2-10. Key drift
- 2-11. Spindle
- 2-12. Bearing ball

Spare Parts Diagram 2

# 13. Parts Lists & Diagrams - Cont.

Spare Parts Diagram 3

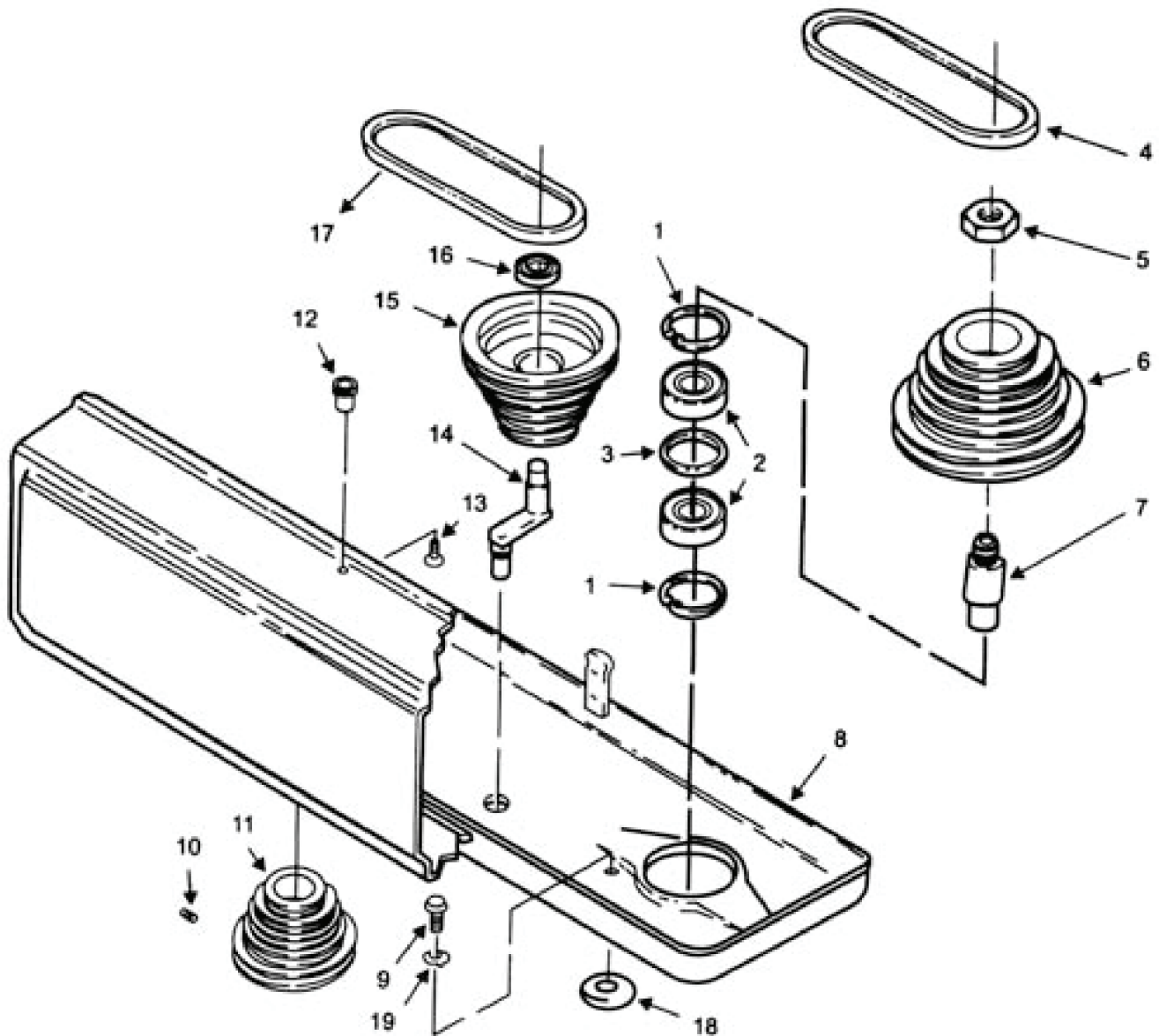

Spare Parts List for Diagram 3

- 3-1. Retaining ring
- 3-2. Bearing ball 25mm
- 3-3. Spacer
- 3-4. Belt "V" M25
- 3-5. Nut pulley
- 3-6. Pulley spindle
- 3-7. Insert spindle
- 3-8. Guard pulley w/labels
- 3-9. Screw RD HD Washer M6x1.0-16
- 3-10. Screw set M10x1.5-12
- 3-11. Motor pulley
- 3-12. Knob
- 3-13. Screw pan HD M5 x 0.8-12
- 3-14. Pivot idler
- 3-15. Pulley centre
- 3-16. Bearing ball 15mm
- 3-17. Belt "V" M26
- 3-18. Foam washer
- 3-19. Lock washer Ext. M6

# 13. 13. Parts Lists & Diagrams - Cont.

Spare Parts Diagram 4

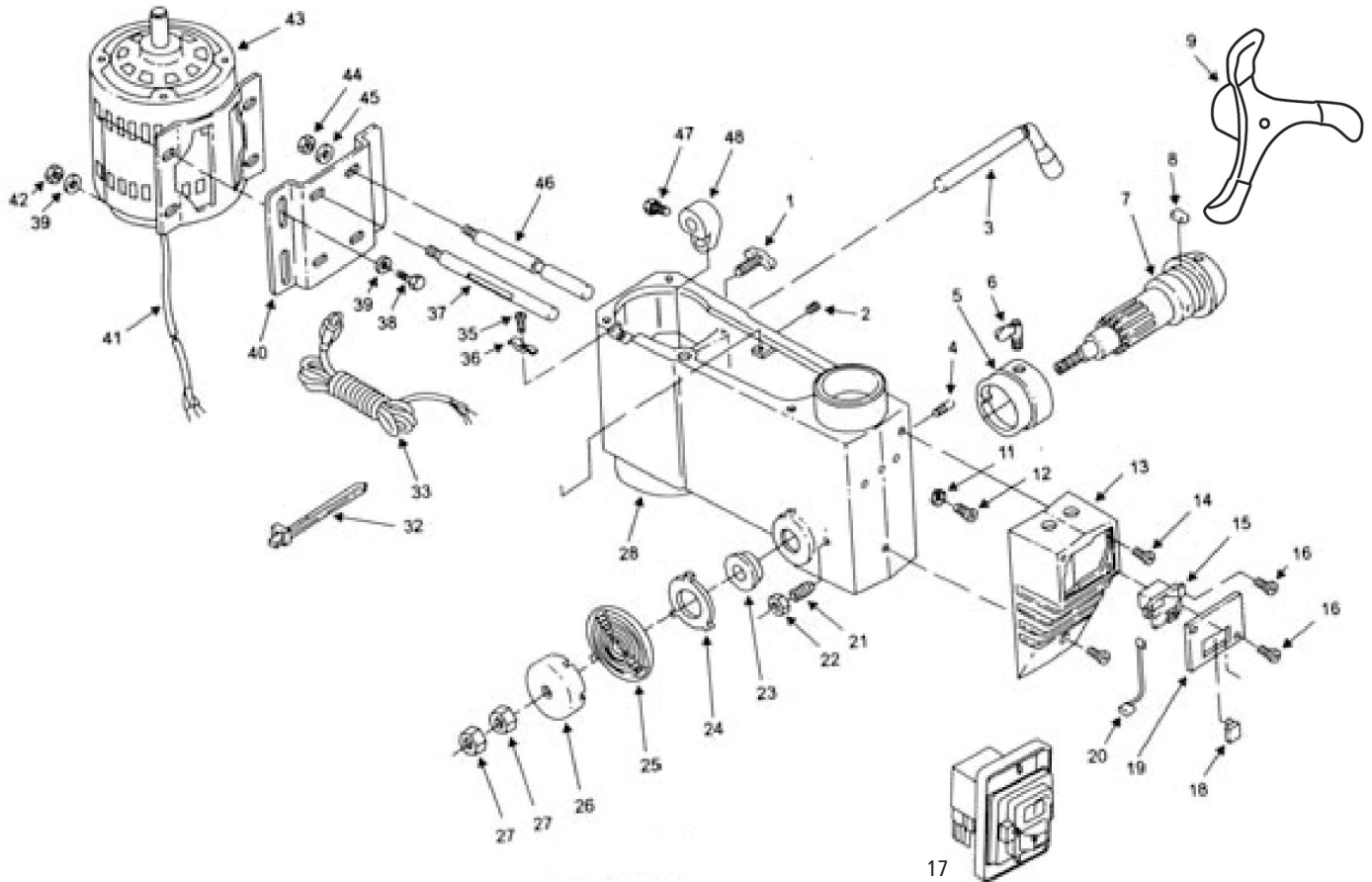

Spare Parts List for Diagram 4

- |                                    |                                     |                                 |
|------------------------------------|-------------------------------------|---------------------------------|
| 4-1. Motor adjusting knob          | 4-17. NVR switch                    | 4-36. Cable clamp               |
| 4-2. Screw socket set M10 x 1.5-12 | 4-18. Switch key                    | 4-37. Motor bracket support     |
| 4-3. Handle belt tension           | 4-19. Switch plate Cover            | 4-38. Hex HD M8 x 1.25-20 screw |
| 4-4. Pin stop                      | 4-20. Lead assembly. 3              | 4-39. Washer 8 x 16 x 1.6       |
| 4-5. Ring depth stop w/scale       | 4-21. Special screw set 10 x 1.5-27 | 4-40. Motor mount               |
| 4-6. Depth screw lock              | 4-22. Nut hex M10 x 1.5             | 4-41. Motor cable               |
| 4-7. Hub                           | 4-23. Seat spring                   | 4-42. Hex M8 x 1.25 nut         |
| 4-8. Guide scale                   | 4-24. Retainer spring               | 4-43. Motor                     |
| 4-9. Feed handle                   | 4-25. Spring torsion                | 4-44. Hex M12 x 1.74 nut        |
| 4-11. Lock washer Ext M5           | 4-26. Spring cap                    | 4-45. Locking washer 1/2        |
| 4-12. Pan HD M5 x -0.8-8 screw     | 4-27. Hex nut M12 x 1.5-8           | 4-46. Support motor bracket     |
| 4-13. Box switch                   | 4-28. Head w/pointer and trim       | 4-47. Screw hex HD M8 x 1.25-16 |
| 4-14. Pan HD M5 x -0.8-16 screw    | 4-32. Tie wire                      | 4-48. Adjusting lever           |
| 4-15. Locking switch               | 4-33. Power cable w/plug            |                                 |
| 4-16. Pan HD M5 x -0.8-16 screw    | 4-35. Pan HD M6 x 1.0-12 screw      |                                 |

# EU Declaration of Conformity

**Cert No: EU / DP58B / 1**

**RECORD POWER LIMITED,**

Centenary House, 11 Midland Way, Barlborough Links,  
Chesterfield, Derbyshire S43 4XA

declares that the machinery described:-

1. Type: **Pedestal Drilling Machine & Bench Top Drilling Machine**
2. Model No: **DP58P & DP58B**
3. Serial No .....

Conforms with the following directives:-

MACHINERY DIRECTIVE (repealing / replacing Directives)	2006/42/EC
LOW VOLTAGE DIRECTIVE	2006/95/EC
ELECTROMAGNETIC COMPATIBILITY DIRECTIVE	2004/108/EC EN 55014-1:2006 EN 61000-3-2:2006 EN 61000-3-3:1995+A1+A2 EN 55014-2:1997+A1

and conforms to the machinery example for which the  
EC Type-Examination Certificate No. **AM50167614, AN50167613, AE50136034**  
at: Am Grauen Stein, D-51105. Cologne, Germany

and complies with the relevant essential health and safety requirements.



Signed.....Dated: **01/04/2014**

**Andrew Greensted**  
Managing Director







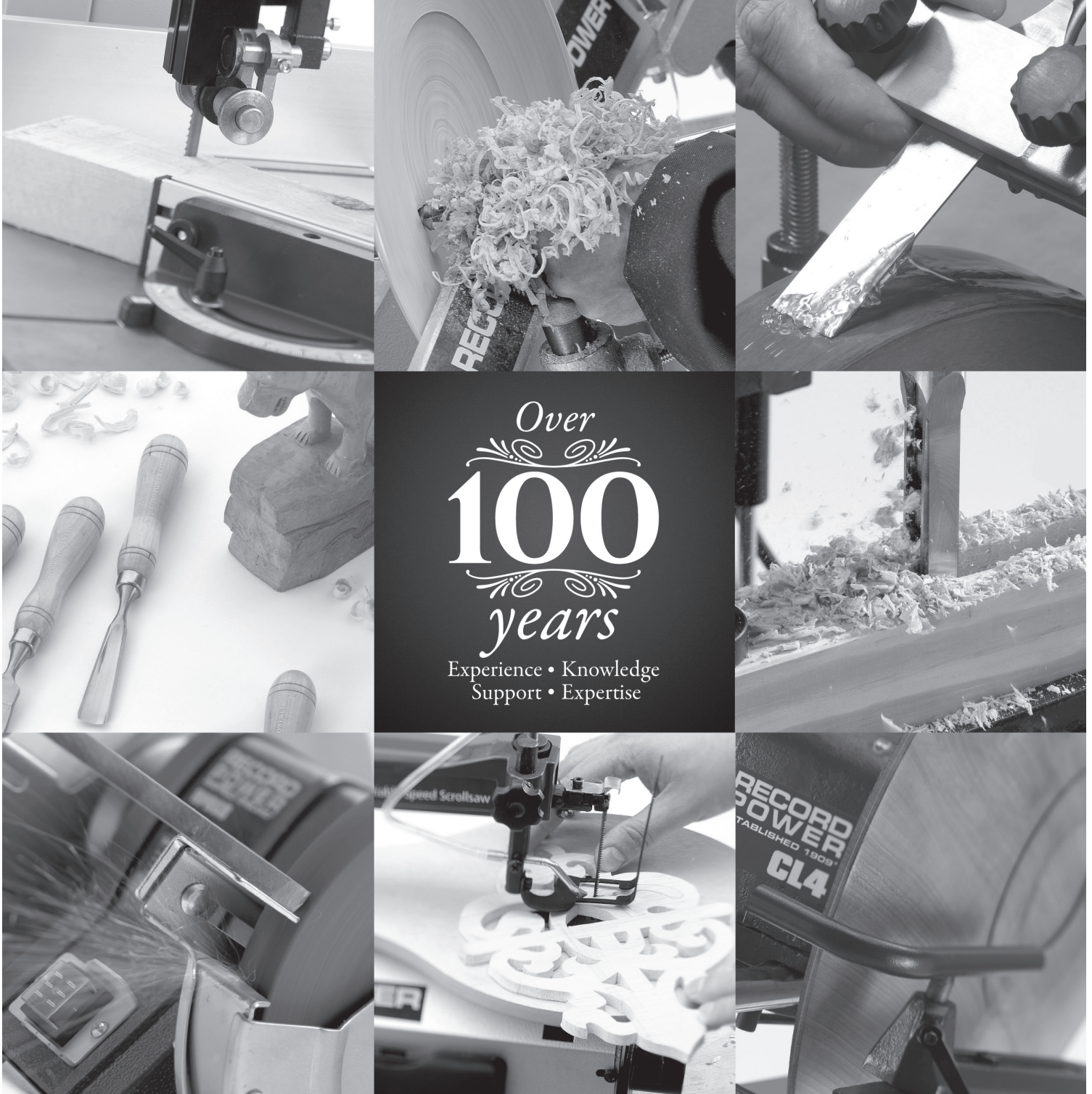

Over  
**100**  
 years

Experience • Knowledge  
 Support • Expertise

**RECORD POWER**  
 ESTABLISHED 1909®

Woodworking Machinery & Accessories

**United Kingdom**

**Record Power Ltd**  
 Centenary House, 11 Midland Way  
 Barlborough Links, Chesterfield  
 Derbyshire S43 4XA  
 Tel: 01246 571 020  
 Fax: 01246 571 030  
 www.recordpower.co.uk

**Eire**

**Record Power Ltd**  
 Centenary House, 11 Midland Way  
 Barlborough Links, Chesterfield  
 Derbyshire S43 4XA  
 Tel: 01246 571 020  
 Fax: 01246 571 030  
 www.recordpower.co.uk

**Australia**

**Tools 4 Industry**  
 Po Box 3844  
 Parramatta 2124  
 Tel: 1300 124 422  
 Fax: 1800 262 725  
 www.recordpower.com.au

**New Zealand**

**Tools 4 Industry**  
 Po Box 276079  
 Manukau City 2241  
 Tel: 0800 142 326  
 Fax: 09 2717 237  
 www.recordpower.co.nz

Made in China