



鸿能海电子
HONGNENGHAI ELECTRONIC

To :

Date : 2021.11.17

TFT LCD

CC08021801-31AA

ACCEPTED BY :

Tentative V0.0

APPROVED BY	CHECKED BY	PREPARED BY

公司地址：深圳市宝安区西乡银田共乐华庭 A 栋 2202

工厂地址：东莞市塘厦镇石潭布大迳一路 10 号

电话：0769-82035588 传真：0769-87905886

Doc.No: CC08021801-31V

Issue Date 2021/11/17



CONTENTS

1. OVERVIEW	4
2. ABSOLUTE MAXIMUM RATINGS.....	5
3. ELECTRICAL CHARACTERISTICS	5
3.1 TFT LCD Power Supply Voltage	5
3.2 TFT-LCD Current consumption	5
3.3 Power on/off sequence	6
3.4 Backlight.....	6
4. INTERFACE CONNECTION	6
5. INTERFACE TIMING CHART	7
5.1 MIPI Interface Timing Sequence	7
5.2 Timing Chart	9
5.3 Reset Input Timing.....	9
5.4 DATA mapping	10
6. MECHANICAL DIMENSION	11
7. OPTICAL CHARACTERISTICS.....	12
8. RELIABILITY TEST	13



1. OVERVIEW

CC08021019-31AA is a 8.0" color TFT-LCD (Thin Film Transistor Liquid Crystal Display) OLB module(finish outer lead bonding) composed of LCD panel, driver ICs (the backlight is not included in this OLB module).

The 8.0" screen produces 800×RGB (3) ×1280 resolution image. By applying R.G.B. input signal, 16.7M color images are displayed.

1.1 LCD Specifications

ITEM	SPECIFICATION
Display Area (mm)	107.64(H)x172.22(V)
Number of Pixels	800(H) x 3(RGB) x 1280(V)
Pixel Pitch (um)	44.85 (H)x3 x134.55(V)
Color Pixel Arrangement	RGB Stripe
Display Mode	Normally Black
Number of Colors	16.7M
Response Time (ms)	30 (typ)
Optimum Viewing Direction	whole view
Contrast Ratio	1500(typ)
Viewing Angle (CR \geq 10)	80°/80°/80°/80°(Typ)
Interface connection	MIPI
Driver IC	JD9365DA-H3
Surface Treatment	-

- Compatible with ROHS Standard



2. ABSOLUTE MAXIMUM RATINGS

The following are maximum values which, if exceeded, may cause faulty operation or damage to the unit.

Item	Symbol	Min.	Max.	Unit	Remark
Power Supply Voltage for I/O	VDDIO	-0.3	3.6	V	
Power Supply Voltage for	VDD-	-0.3	3.6	V	
Positive Voltage	-	-	-	V	
Negative Voltage	-	-	-	V	

Note1 : If users use the product out off the environmental operation range (temperature and humidity) , it will have visual quality concerns.

3. ELECTRICAL CHARACTERISTICS

3.1 TFT LCD Power Supply Voltage

(GND=VSSA=VSSD=0V)

Ta=25°C

I/O Operating Voltage	VDDIO	1.7	1.8	1.9	V	
Analog Operating Voltage	VDD-	3.0	3.3	3.6	V	
Analog Operating Voltage	-	-	--	-	V	
Input Signal Voltage	VIH	0.7* VDD	--	VDD	V	
	VIL	GND	--	0.3* VDD	V	
Output Signal Voltage	VOH	0.8* VDD	--	VDD	V	
	VOL	GND	--	0.2* VDD	V	

3.2 TFT-LCD Current consumption

(GND=VSSA=VSSD=0V)

Ta=25°C

ITEM	SYMBOL	Condition	MIN	TYPE	MAX	UNIT	NOTE
Current For Driving	I _{VDD}	VDDIO	-	30		mA	
	I _{VBAT_SYS}	VDD		130		mA	
Total Power Consumption	PC		-	460		mW	Note1

Note1: Typ. specification : : Gray-level test Pattern

Max. specification : White test Pattern



(a) Gray-level Pattern



(b) White Pattern



3.3 Power on/off sequence

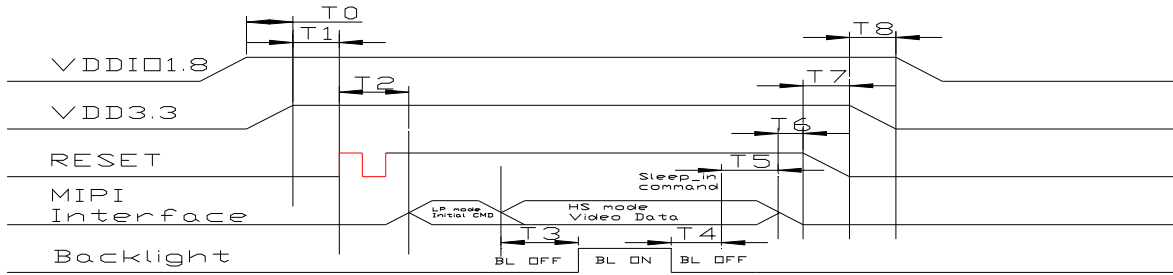

Parameter	Min	Value		Unit	Remark
		Typ	Max		
T0				333	
T1				333	
T2				333	
T3	100			333	
T4	50			333	
T5	100			333	
T6				333	
T7				333	
T8				333	

3.4 Backlight

Ta=25 °C

ITEM	SYMBOL	CONDITIONS	MIN	TYP	MAX	UNIT	NOTE
LED current	IL	Ta=25 °C	--	140	--	mA	
LED voltage	VL	Ta=25 °C	--	9	--	V	
Power consumption	WL	Ta=25 °C	--	1.428	--	W	
LED Lifetime	-	Ta=25 °C	--	15000	--	Hr	

【Note】

*1)LED Circuit Diagram:

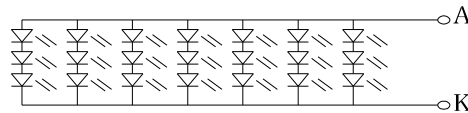

Backlight LED Circuit $I_F = 140\text{mA}$; $V_f = 9\text{V}$

*2) Calculator value for reference $I_F \times V_f \times N = P_{LED}$

*3) Life time means that estimated time to 50% degradation of initial luminous intensity.

*4) In order to prevent module brightness or screen display unstable, LED shall be controlled under constant current.

4. INTERFACE CONNECTION

CN (Interface signal)

Connector type: FH26-31S-0.3SHW(**) or compatible

Pin No.	Pin Name	Description
1	LED+	Power supply for LED[Anode]
2	LED+	Power supply for LED[Anode]
3	LED+	Power supply for LED[Anode]
4	NC	No Connect
5	LED-	Power supply for LED[Cathode]
6	LED-	Power supply for LED[Cathode]
7	LED-	Power supply for LED[Cathode]
8	LED-	Power supply for LED[Cathode]
9	GND	Ground
10	GND	Ground



11	MIPI_2P	MIPI data positive signal(2P)
12	MIPI_2N	MIPI data negative signal(2N)
13	GND	Ground
14	MIPI_1P	MIPI data positive signal(1P)
15	MIPI_1N	MIPI data positive signal(1N)
16	GND	Ground
17	MIPI_CLKP	MIPI CLK positive signal(CLKP)
18	MIPI_CLKN	MIPI CLK positive signal(CLKN)
19	GND	Ground
20	MIPI_0P	MIPI data positive signal(0P)
21	MIPI_0N	MIPI data positive signal(0N)
22	GND	Ground
23	MIPI_3P	MIPI data positive signal(3P)
24	MIPI_3N	MIPI data positive signal(3N)
25	GND	Ground
NOTE:1		
26	NC	NC
27	RESET	Reset Pin (1.8V)
28	NC	NC
29	VDDIO	Logic power 1.8V
30	VDD	Logic power 3.3V
31	VDD	Logic power 3.3V
NOTE:2		
26	NC	NC
27	RESET	Reset Pin (3.3V)
28	NC	NC
29	VDDIO	Logic power 3.3V
30	VDD	Logic power 3.3V
31	VDD	Logic power 3.3V

5. INTERFACE TIMING CHART

5.1 MIPI Interface Timing Sequence

(a) MIPI interface DC characteristic

DC characteristics for MIPI LP mode

Parameter	Symbol	Spec.			Unit
		Min.	Typ.	Max.	
Logic 1 input voltage	V_{IH}	880	-	-	mV
Logic 0 input voltage	V_{IL}	0	-	550	mV
Logic 1 output voltage	V_{OH}	1.1	1.2	1.3	V
Logic 0 output voltage	V_{OL}	-50	-	50	mV

DC characteristics for MIPI HS mode

Parameter	Symbol	Spec.			Unit
		Min.	Typ.	Max.	
Common-mode voltage HS Receive mode	V_{CMRXDC}	70	-	330	mV
Differential input high threshold ⁽¹⁾	V_{IDTH}	-	-	70	mV
Differential input low threshold ⁽¹⁾	V_{IDTL}	-70	-	-	mV
Single-ended input high voltage	V_{IHHS}	-	-	460	mV
Single-ended input low voltage	V_{ILHS}	-40	-	-	mV
Differential input impedance	Z_{ID}	80	100	125	Ω
HS transmit differential voltage (VDP-VDN)	VOD	140	200	270	mV

Note: (1) VIDTH and VIDTL only for reference, related to power and ground noise, this spec need to check on panel performance to fine tune

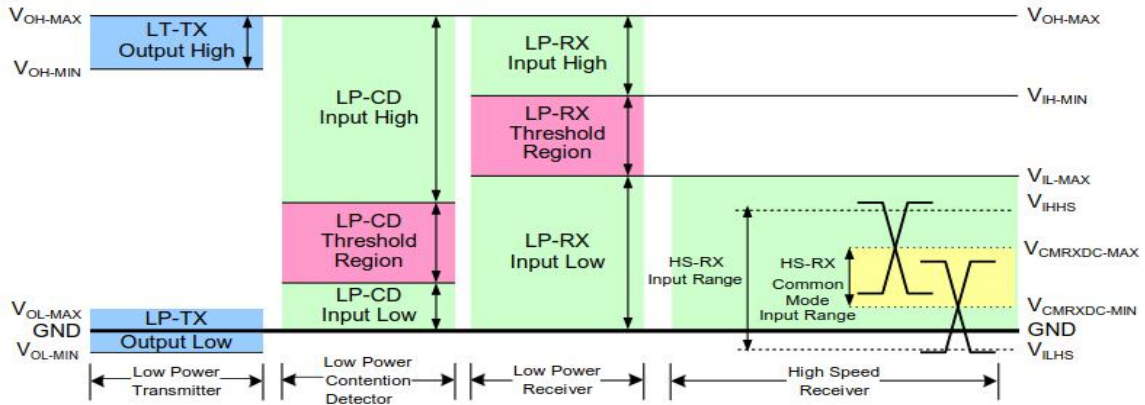

Figure. MIPI signaling and contention voltage levels

(b) MIPI interface AC characteristics

MIPI data-clock timing specification

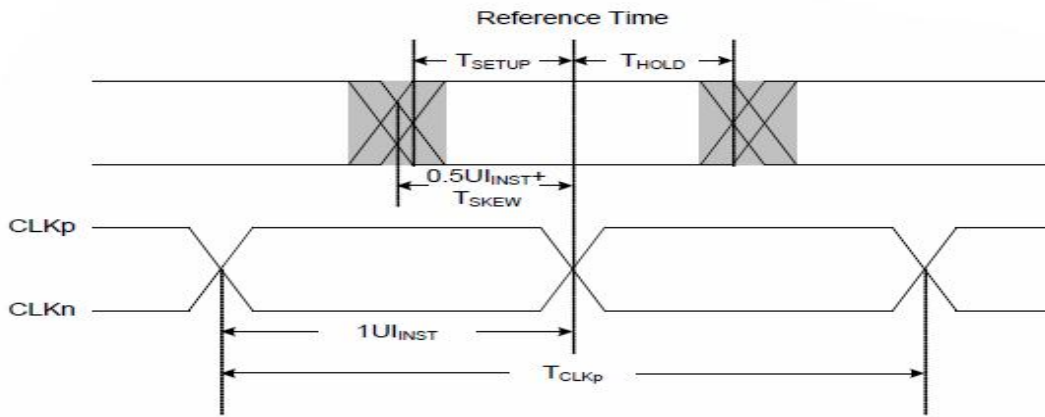

Figure 8.5 : Data to clock timing

Parameter	Symbol	Spec.			Unit
		Min.	Typ.	Max.	
UI instantaneous	UI_{INST}	1.0	-	12.5 ⁽¹⁾	ns
Data to clock setup time	T_{SETUP}	0.15 ⁽²⁾	-	-	UI_{INST}
Data to clock hold time	T_{HOLD}	0.15 ⁽²⁾	-	-	UI_{INST}

Note: (1) This value corresponds to a minimum 80 Mbps data rate.
(2) Total SETUP and HOLD window for receiver of $0.3 \cdot UI_{INST}$



5.2 Timing Chart

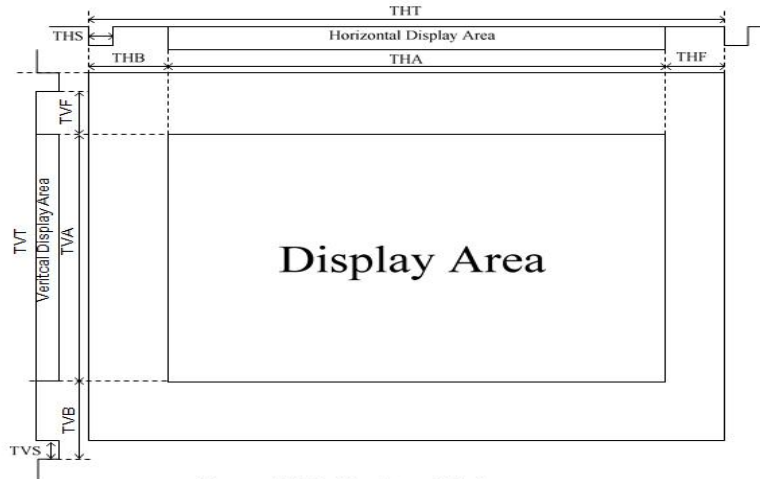
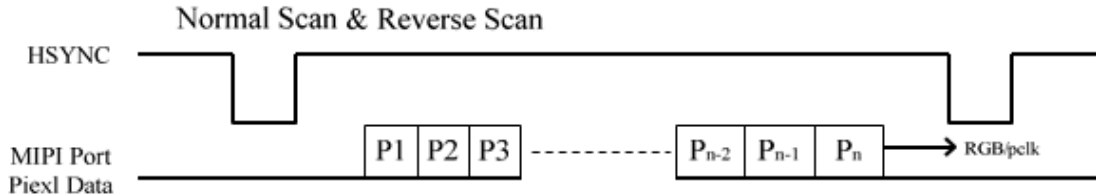

Figure: MIPI video input timing

MIPI Multi-Drop type when normal or reverse scan.



Input Timing	Symbol	800RGBx1280			Unit
		Min.	Typ.	Max.	
PCLK Frequency	-	-	67.84		MHz
Horizontal Total	THT		854		DCLK
Horizontal Synchronization	THS		18		DCLK
Horizontal Back Porch	THB		18		DCLK
Horizontal Address	THA		800		DCLK
Horizontal Front Porch	THF		18		DCLK
Vertical Frequency	-		60		Hz
Vertical Total(1)	TVT		1324		THT
Vertical Synchronization	TVS		4		THT
Vertical Back Porch	TVB		12		THT
Vertical Address	TVA		1280		THT
Vertical Front Porch	TVF		24		THT

5.3 Reset Input Timing

t_{RESW} shorter than 75us, Reset will be rejected.

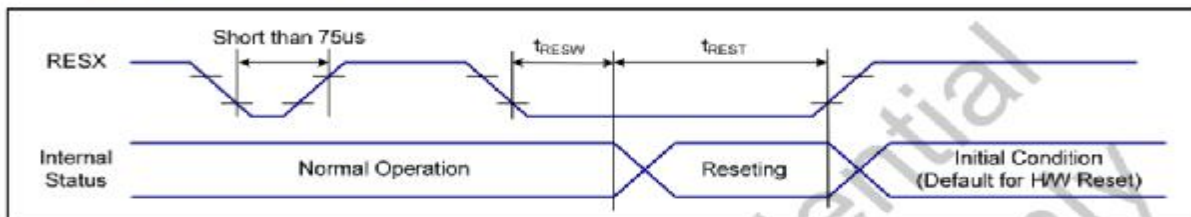

VSS=0V, VDDI=1.65V to 1.95V, Ta = -30°C to 70°C

Symbol	Parameter	MIN	TYP	MAX	Note	Unit
t_{RESW}	*1) Reset low pulse minimum width	150	-	-	Reset signal recognized	us
t_{REST}	*2) Reset complete time	5	-	120	Reset action complete	ms



5.4 DATA mapping

COLOR	INPUT DATA	R DATA								G DATA								B DATA							
		R7 MSB	R6	R5	R4	R3	R2	R1	R0 LSB	G7 MSB	G6	G5	G4	G3	G2	G1	G0 LSB	B7 MSB	B6	B5	B4	B3	B2	B1	B0 LSB
BASIC COLOR	BLACK	0	0	0	0	0	0	0	0	0	0	0	0	0	0	0	0	0	0	0	0	0	0	0	0
	RED(255)	1	1	1	1	1	1	1	1	0	0	0	0	0	0	0	0	0	0	0	0	0	0	0	
	GREEN(255)	0	0	0	0	0	0	0	0	1	1	1	1	1	1	1	0	0	0	0	0	0	0	0	
	BLUE(255)	0	0	0	0	0	0	0	0	0	0	0	0	0	0	0	1	1	1	1	1	1	1	1	
	CYAN	0	0	0	0	0	0	0	0	1	1	1	1	1	1	1	1	1	1	1	1	1	1	1	
	MAGENTA	1	1	1	1	1	1	1	1	0	0	0	0	0	0	0	1	1	1	1	1	1	1	1	
	YELLOW	1	1	1	1	1	1	1	1	1	1	1	1	1	1	1	0	0	0	0	0	0	0	0	
	WHITE	1	1	1	1	1	1	1	1	1	1	1	1	1	1	1	1	1	1	1	1	1	1	1	
RED	RED(0)	0	0	0	0	0	0	0	0	0	0	0	0	0	0	0	0	0	0	0	0	0	0	0	
	RED(1)	0	0	0	0	0	0	0	1	0	0	0	0	0	0	0	0	0	0	0	0	0	0	0	
	RED(2)	0	0	0	0	0	0	1	0	0	0	0	0	0	0	0	0	0	0	0	0	0	0	0	
	RED(254)	1	1	1	1	1	1	1	0	0	0	0	0	0	0	0	0	0	0	0	0	0	0	0	
	RED(255)	1	1	1	1	1	1	1	1	0	0	0	0	0	0	0	0	0	0	0	0	0	0	0	
GREEN	GREEN(0)	0	0	0	0	0	0	0	0	0	0	0	0	0	0	0	0	0	0	0	0	0	0	0	
	GREEN(1)	0	0	0	0	0	0	0	0	0	0	0	0	0	0	1	0	0	0	0	0	0	0	0	
	GREEN(2)	0	0	0	0	0	0	0	0	0	0	0	0	0	1	0	0	0	0	0	0	0	0	0	
	GREEN(254)	0	0	0	0	0	0	0	0	1	1	1	1	1	1	0	0	0	0	0	0	0	0	0	
	GREEN(255)	0	0	0	0	0	0	0	0	1	1	1	1	1	1	1	0	0	0	0	0	0	0	0	
BLUE	BLUE(0)	0	0	0	0	0	0	0	0	0	0	0	0	0	0	0	0	0	0	0	0	0	0	0	
	BLUE(1)	0	0	0	0	0	0	0	0	0	0	0	0	0	0	0	0	0	0	0	0	0	0	1	
	BLUE(2)	0	0	0	0	0	0	0	0	0	0	0	0	0	0	0	0	0	0	0	0	0	1	0	
	BLUE(254)	0	0	0	0	0	0	0	0	0	0	0	0	0	0	0	1	1	1	1	1	1	1	0	
	BLUE(255)	0	0	0	0	0	0	0	0	0	0	0	0	0	0	0	1	1	1	1	1	1	1	1	

【Note】

- 1) Gray level:
Color(n) : n is level order; higher n means brighter level.
- 2) DATA:
1: high · 0: low



6. MECHANICAL DIMENSION



东莞鸿能海电子制品有限公司
DONGGUANG HONGNENGHAI ELECTRONIC PRODUCTS CO., LTD.

模组图

DIMENSIONAL TOLERANCE(±)						
尺寸范围(±)						
公差等级	0 ₁ 5	5 ₁ 15	15 ₁ 60	60 ₁ 150	150 ₁ 300	300 ₁ 630
□ A	0.05	0.10	0.15	0.20	0.25	0.30
☑ B	0.10	0.15	0.20	0.25	0.30	0.35

UNLESS OTHERWISE SPECIFIED
没指定尺寸

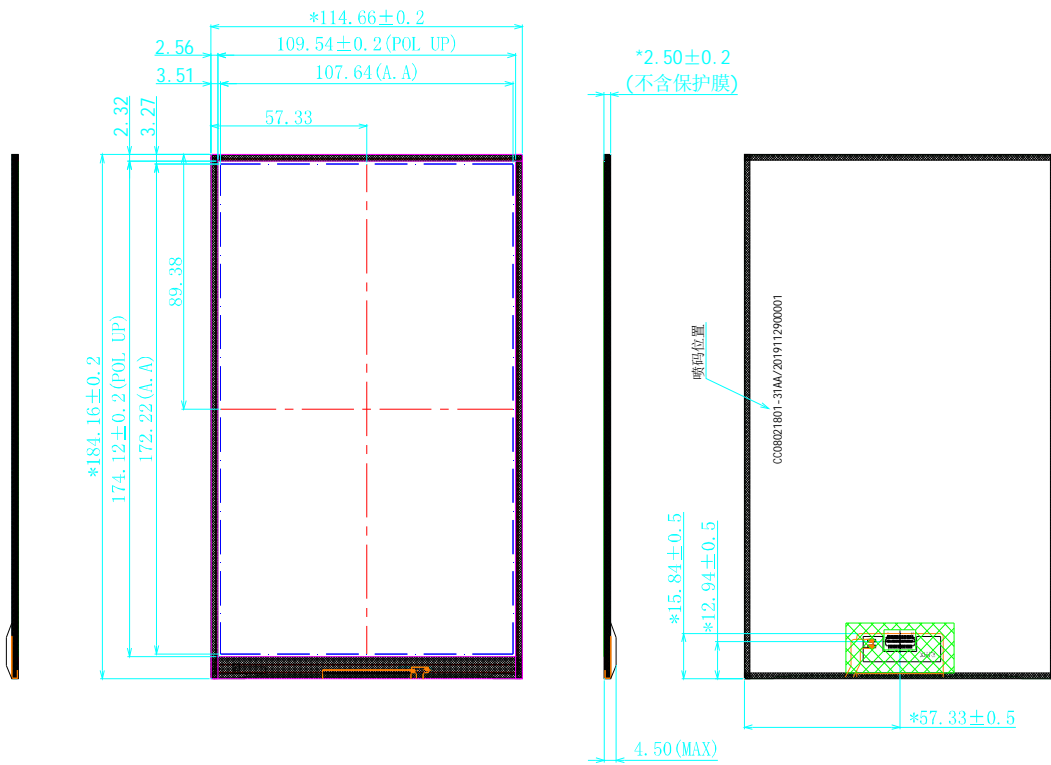

BM-7测试(撕掉FOG上保护膜后)

参数	SYMBOL	MIN	TYP	MAX	单位	备注
中心点亮度	Iv ■ LCM	250	300		cd/m2	IF=140mA
	Iv ■ LCM					
背光色坐标范围	X					
	Y					
模组坐标范围	X	0.260	0.310	0.360		
	Y	0.280	0.330	0.380		
驱动电压	Vf	7.8	9.0	10.2	V	
反向电流	Ir			50	uA	V _R =10V, ※1
均匀性	Iv-m	75	80		%	(min/max)*100
最大额定功率				1428	mW	

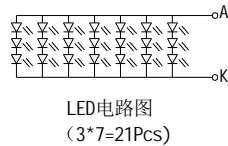

REVISION 版本	A0	<input checked="" type="checkbox"/> 正式规格	<input type="checkbox"/> 临时规格	REVISE 修订人	MODEL NO 产品料号	APPROVED BY 核准	CHECKED BY 审核	DRAWN BY 绘图
DATE 日期	2021.11.15			李恭全	CC08021801-31AA			
PAGE 页码	2/4							



7. OPTICAL CHARACTERISTICS

Ta = 25°C, VCC=3.3V

ITEM	SYMBOL	CONDITION	MIN.	TYP.	MAX.	UNIT	NOTE		
Luminance	L		250	300	--	cd/m ²	Note 1		
Contrast	CR		1200	1500	--	--	Note2		
Response Time	Tr+Tf	$\theta=\phi= 0^\circ$	--	30	35	ms	Note 3		
Viewing Angle	Vertical	U	CR ≥ 10	75	80	--	degree	Note 4	
		D		75	80	--	degree		
	Horizontal	L		75	80	--	degree		
		R		75	80	--	degree		
Color Filter Chromaticity	W	x	$\theta=\phi= 0^\circ$	(0.273)	(0.303)	(0.313)	--	Note 5	
		y		(0.298)	(0.328)	(0.358)	--		
	R	x		(0.604)	(0.634)	(0.664)	--		
		y		(0.304)	(0.334)	(0.364)	--		
	G	x		(0.256)	(0.286)	(0.316)	--		
		y		(0.506)	(0.536)	(0.566)	--		
	B	x		(0.110)	(0.140)	(0.170)	--		
		y		(0.073)	(0.103)	(0.133)	--		
	NTSC					56.9	---		%
	Flicker					-30	-15		dB
Crosstalk				2	3	%			

Note1: Measure condition : 25°C±2°C , 60±10%RH , under10 Lux in the dark room.BM-7 (TOPCON) , viewing angle2° , IL=90mA (Backlight current) measurement after lighting on 10 mins.

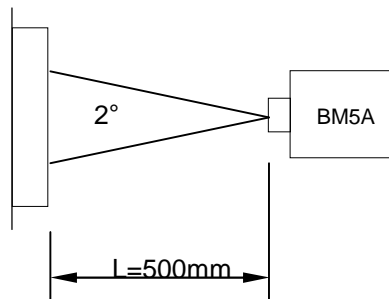

Note 2 Definition of Contrast Ratio :

Contrast ratio is calculated with the following formula.

Contrast ratio (CR)= White Luminance (ON) / Black Luminance (OFF)

Note 3 Definition of response time

The output signals of photo detector are measured when the input signals are changed from “black” to “white” (rising time) and from “white” to “black” (falling time), respectively. Definition of response time : The response time is defined as the time interval between the 10% and 90% amplitudes.

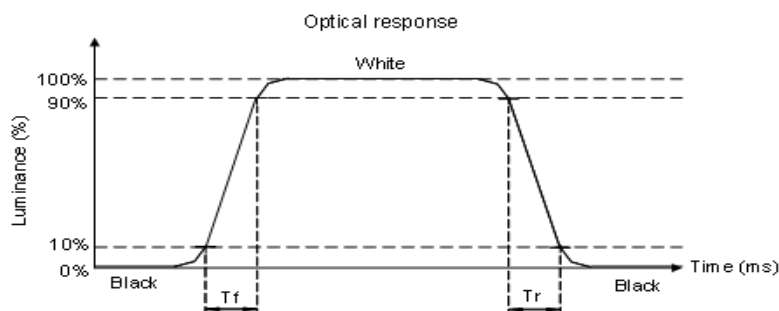



Note 4 Definition of view angle(θ · ψ)

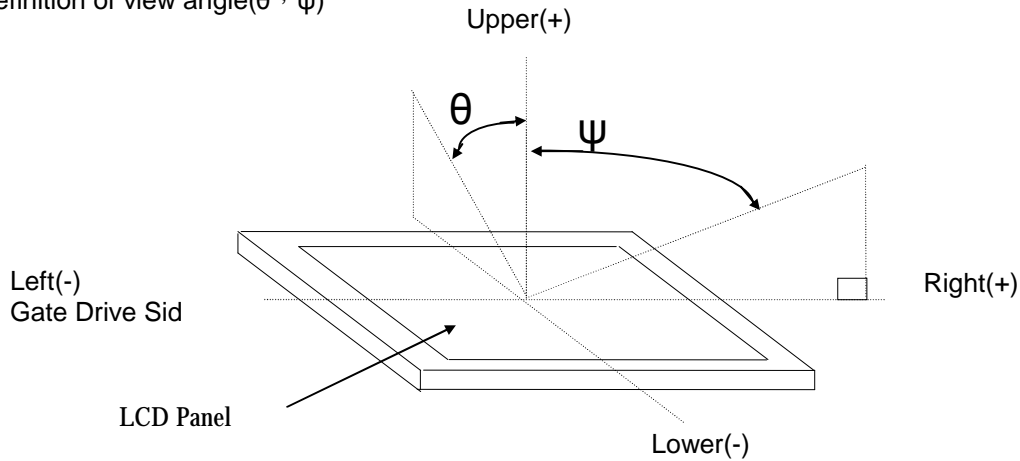

Note 5. (a) CF Glass light source: C light.

(b) Chromaticity & NTSC spec is for reference. (Different polarizer & backlight will both affect the MODULE chromaticity.)

Note 6. Definition of Luminance and Luminance uniformity

Central luminance: The white luminance is measured at the center position "5" on the screen, see Fig below.

9P Uniformity: $\Delta L = (L_{min} / L_{max}) \times 100\%$ at measuring points 1 & 9 see Fig below.

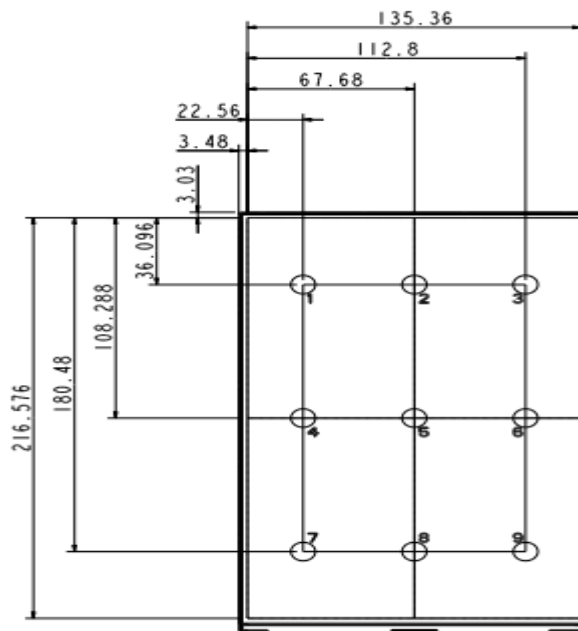

8. RELIABILITY TEST

TEST ITEMS	CONDITIONS	NOTE
High Temperature Operation	50°C,96hrs	1
High Temperature Storage	60°C,96hrs	1
High Temperature High Humidity Operation	50°C,90%RH,96hrs	No condensation
Low Temperature Operation	-10°C,96hrs	1
Low Temperature Storage	-20°C,96hrs	1
Thermal Shock	-20°C(0.5hr) ~ 60°C(0.5hr) ,50 Cycles	Non-Operating

NOTE

- All judgement of display are performed after temperature of panel return to room temperature.
- Display function should be no change under normal operating condition.
- Under no condensation of dew.
- HNH only guarantee the above 6 test items, and without guarantee the others.